

8/16-Bit Single Chip Microcontroller

Microcomputer

78K Series

- ◆ *78K/0S Series Products*
- ◆ *78K/0 Series Products*
- ◆ *78K/II Series Products*
- ◆ *78K/III Series Products*
- ◆ *78K/IV Series Products*

PRODUCTS

78K Series

ROAD MAP

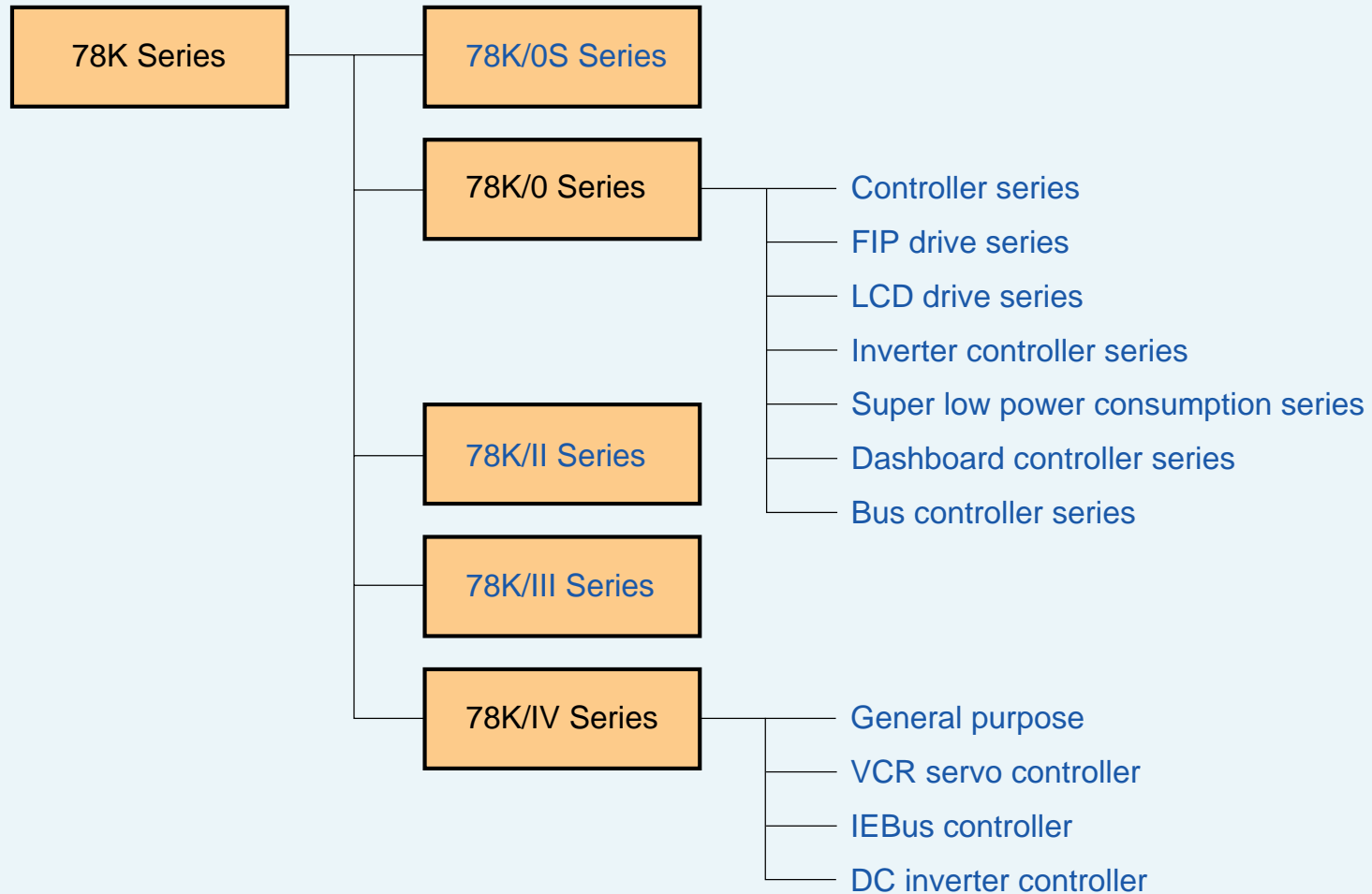

78K/0S Series

ROAD MAP

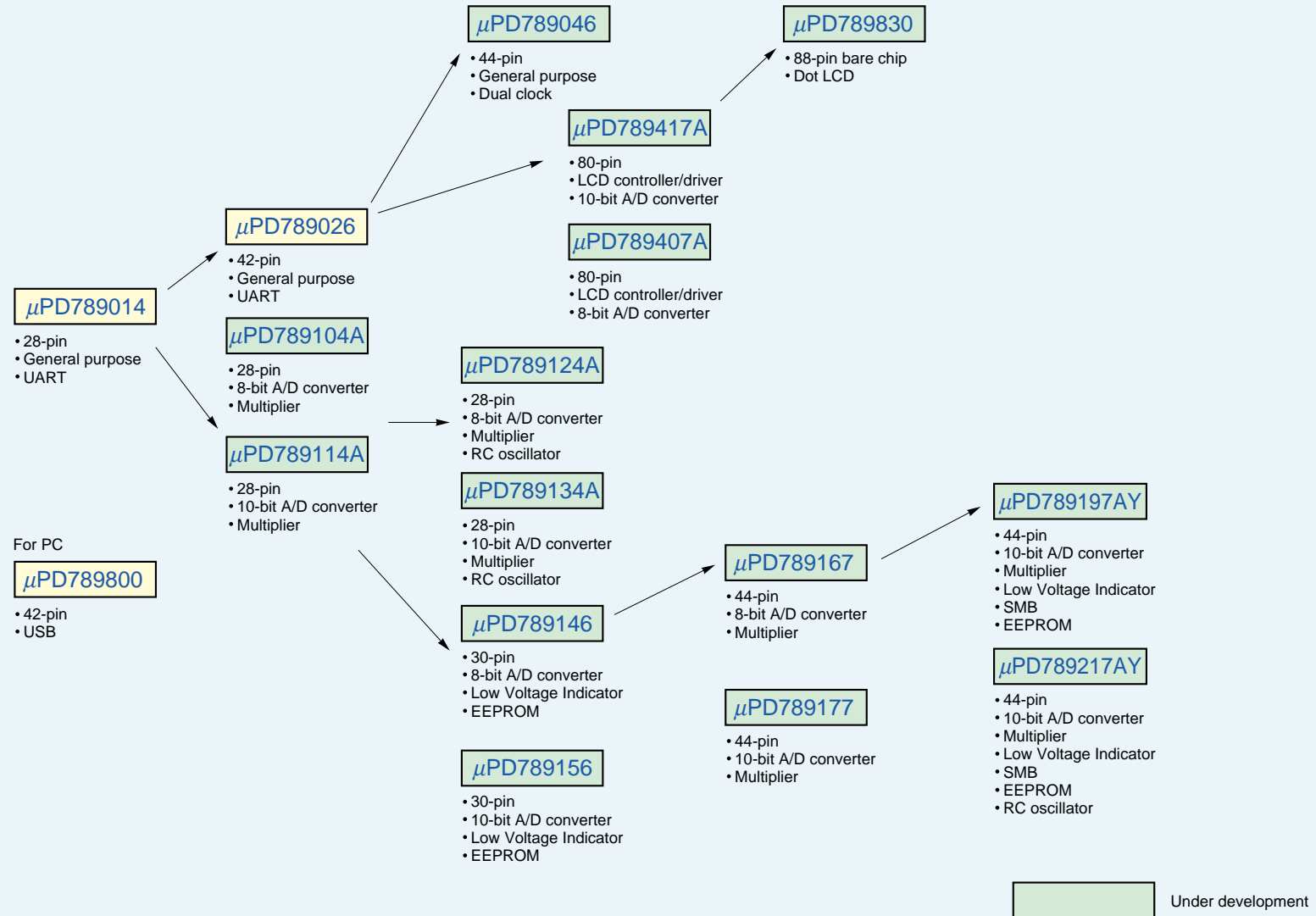

78K/0 Series : Controller Series

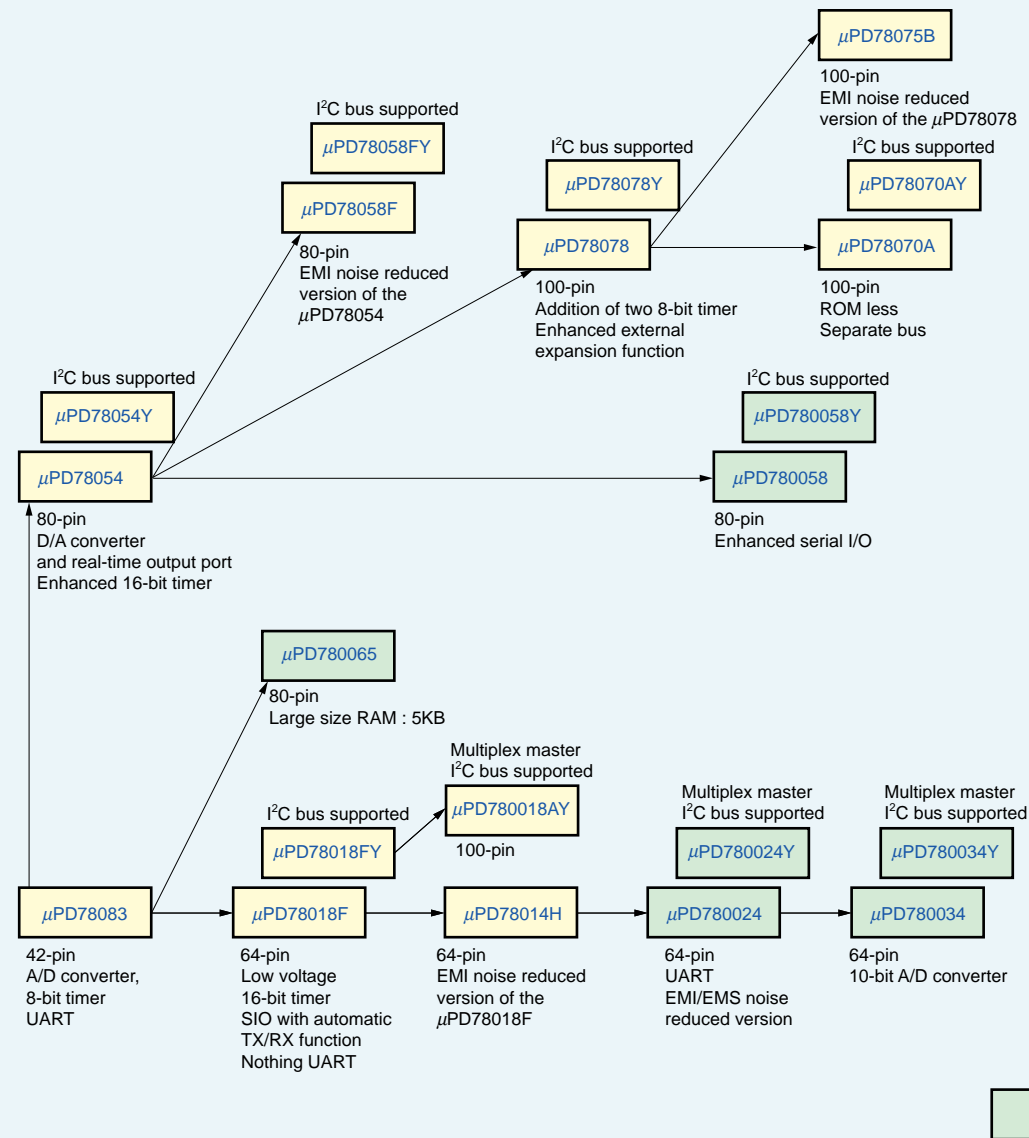

78K/0 Series : FIP Drive Series

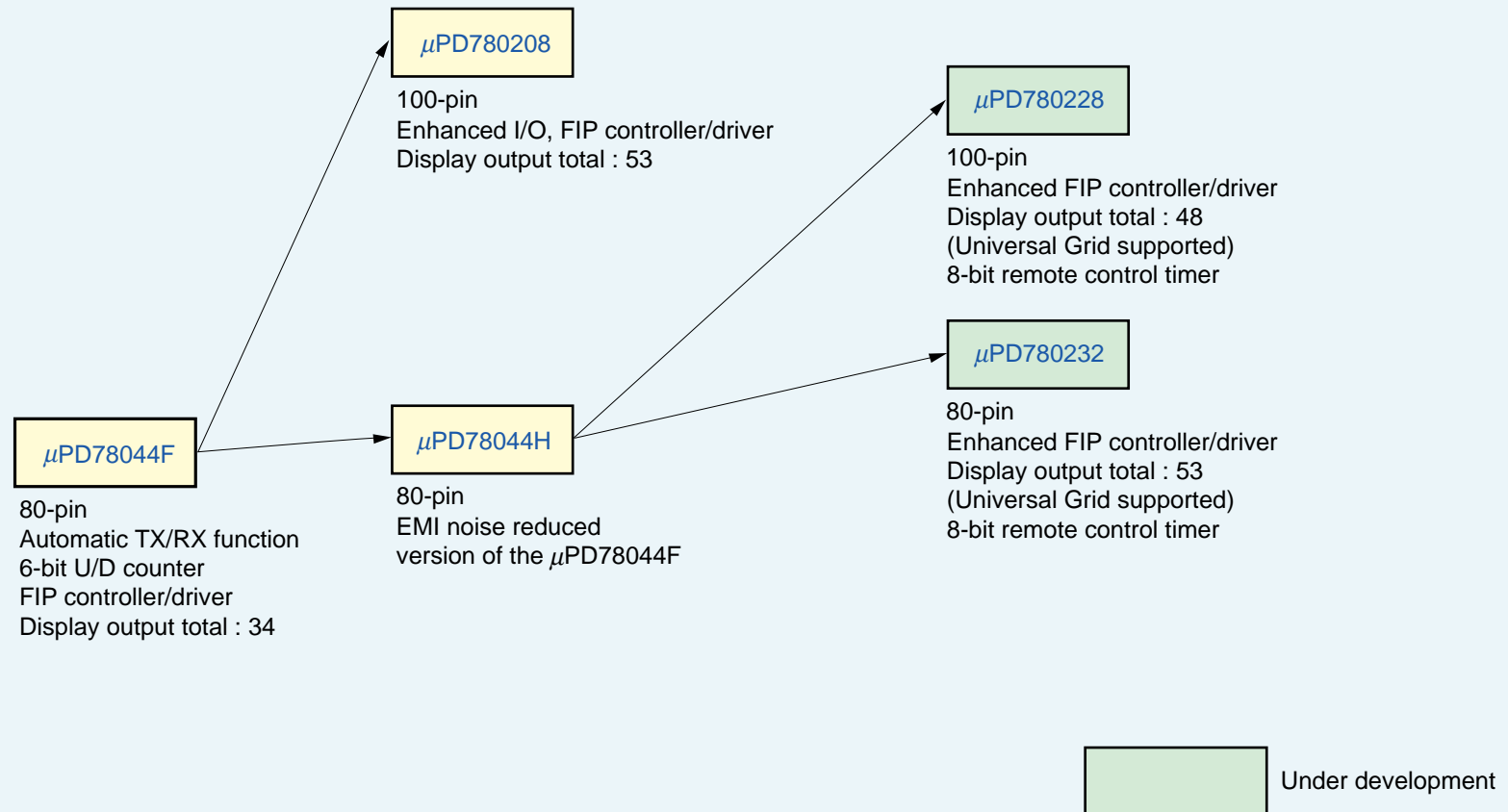

78K/0 Series : LCD Drive Series

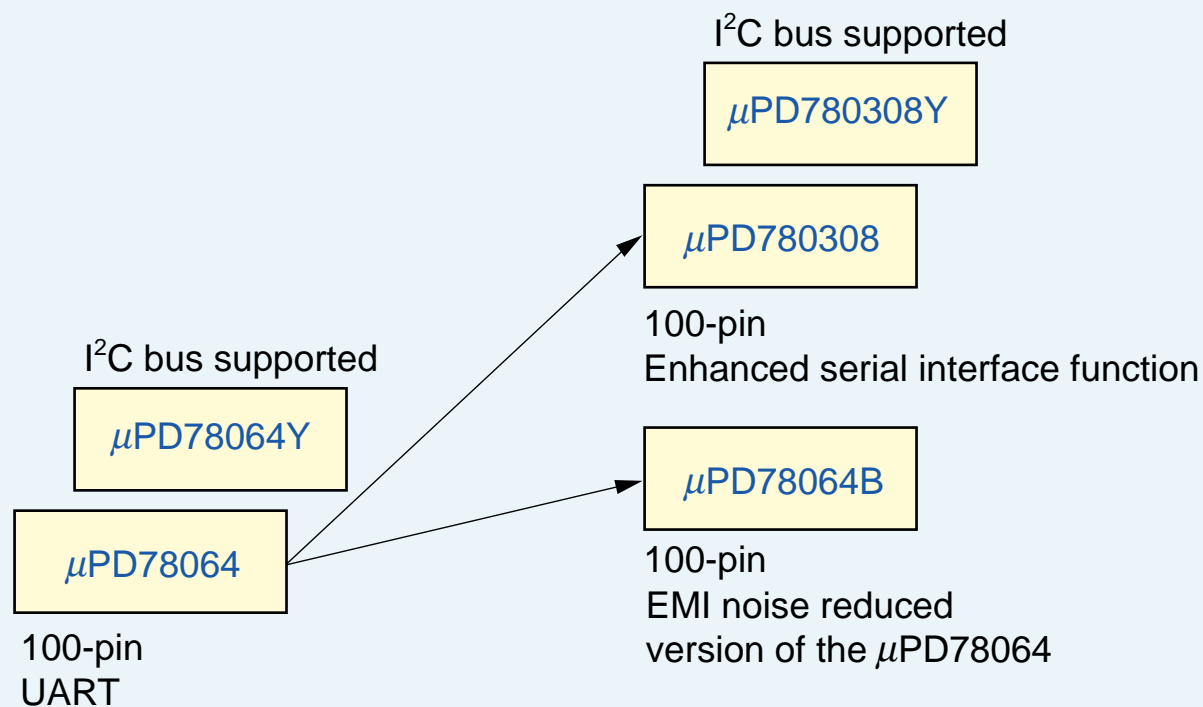

78K/0 Series : Inverter Controller Series, Super Low Power Consumption Series, Dashboard Controller Series

Inverter controller series

μ PD780988

64-pin
10-bit A/D converter

Super low power consumption series

μ PD780955

80-pin
Consumption current : 3.4 μ A typical (operation)
1.1 μ A typical (HALT)

Dashboard controller series

μ PD780973

80-pin
Meter controller/driver



Under development

78K/0 Series : Bus Controller Series

μ PD78098B

80-pin
IEBus controller

μ PD780701Y

80-pin

(μ PD780701Y : DCAN controller
 μ PD780702Y : IEBus controller
 μ PD78F0701Y : DCAN or IEBus controller)

μ PD780833Y

80-pin
J1850 (CLASS2) controller

μ PD780948

100-pin
DCAN controller



Under development

78K/II Series

ROAD MAP

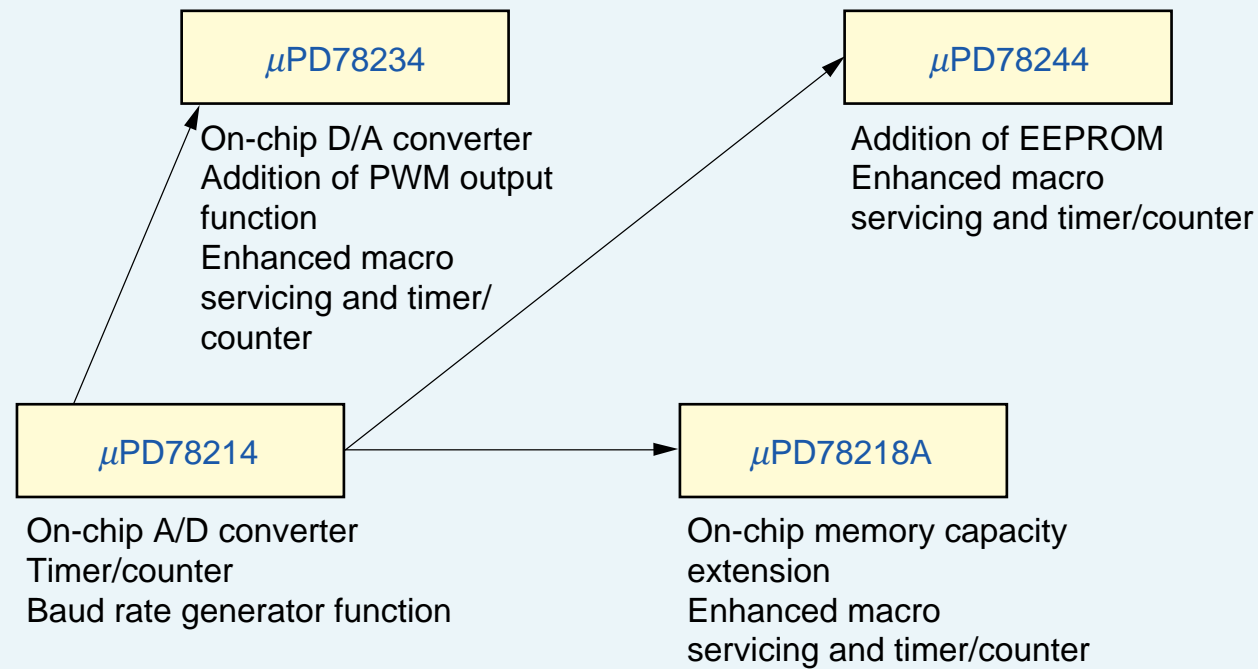

78K/III Series

ROAD MAP

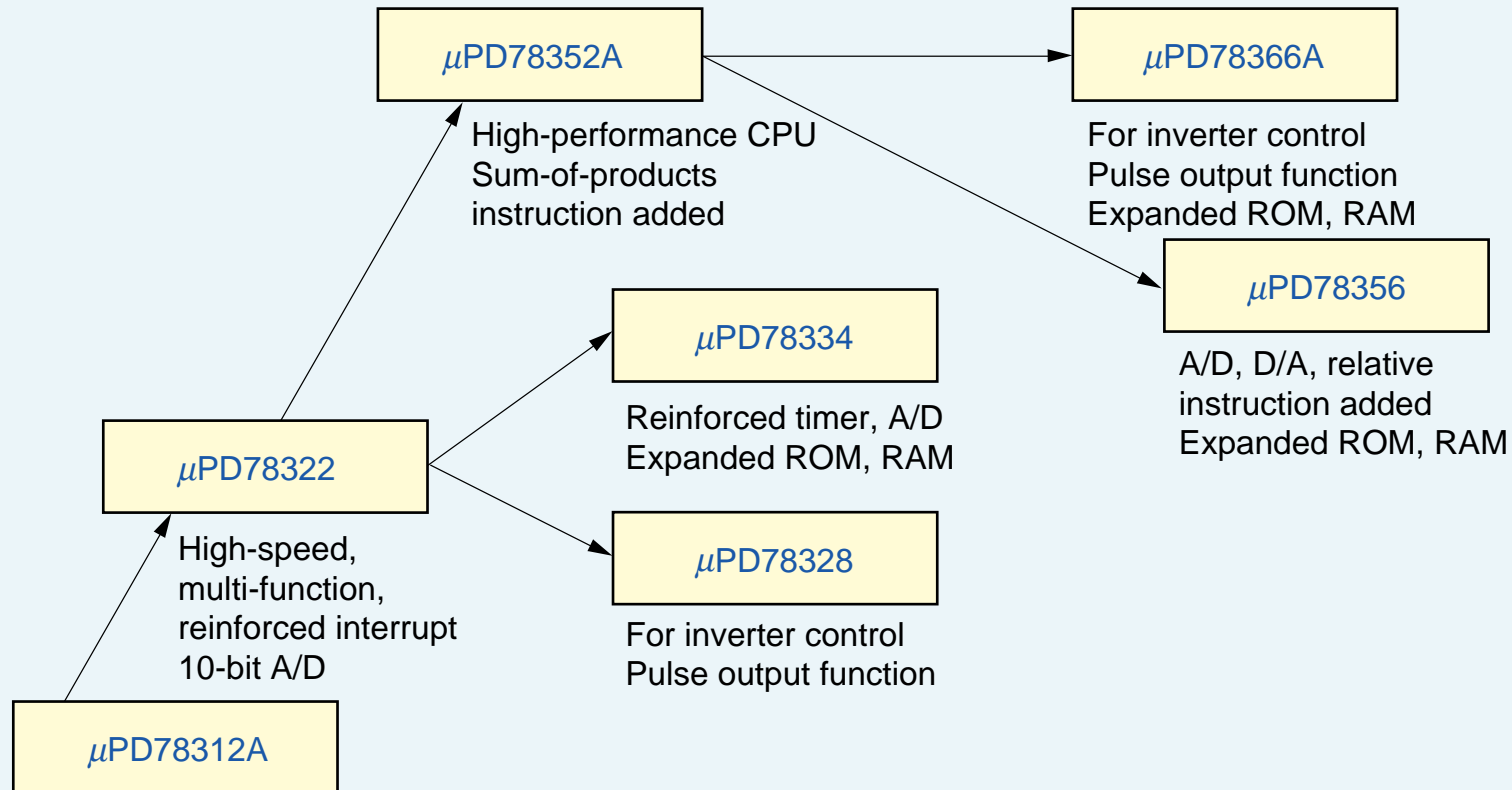

78K/IV Series : General Purpose

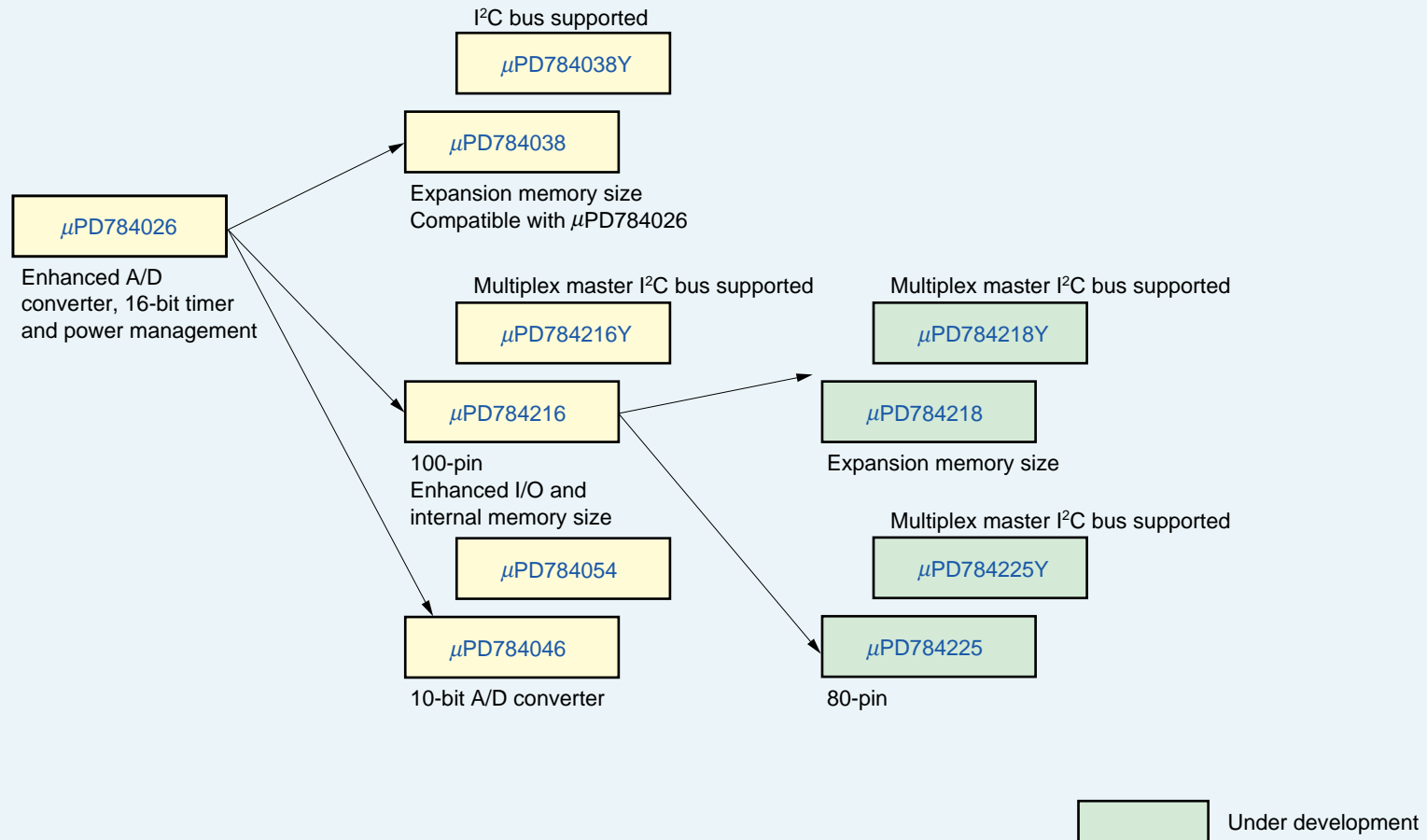

78K/IV Series : VCR Servo Controller

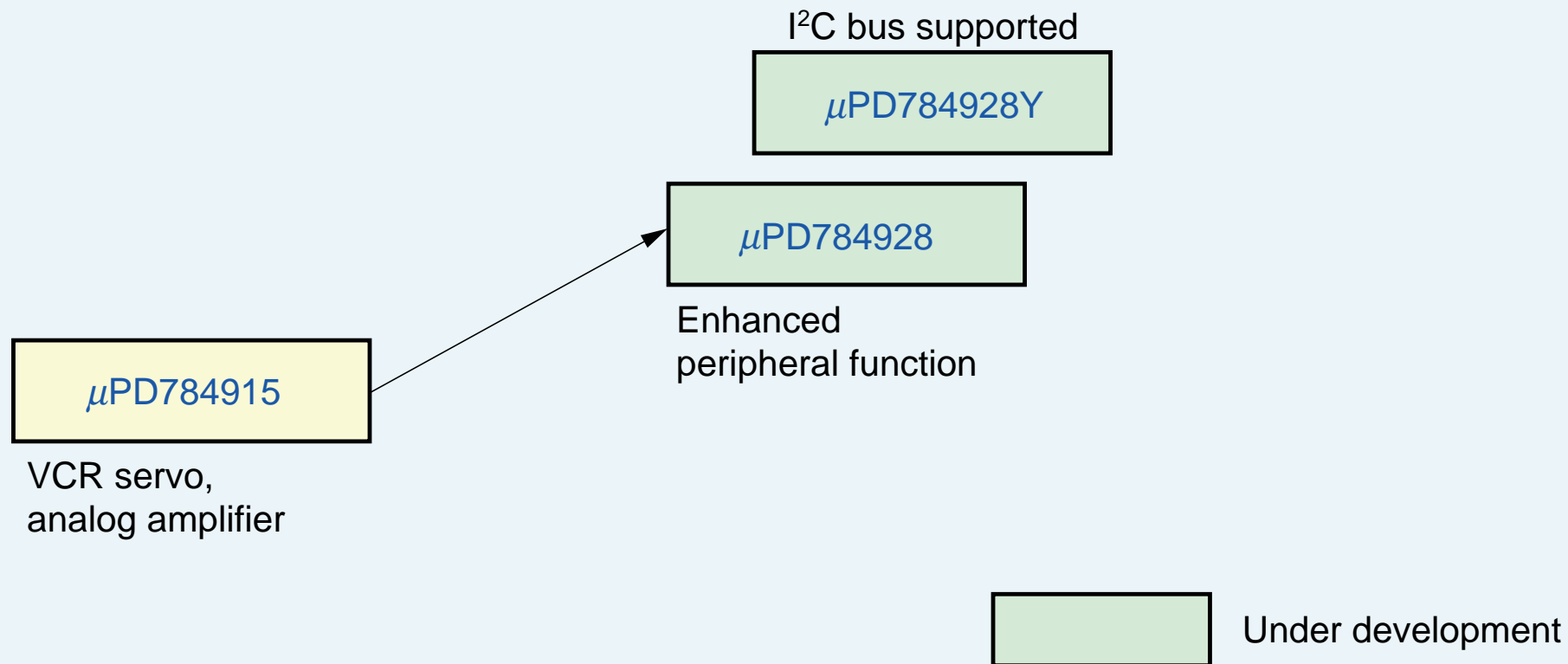

78K/IV Series : IEBus Controller, DC Inverter Controller

IEBus controller

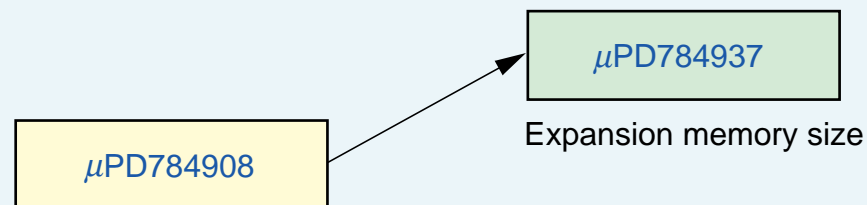

DC inverter controller

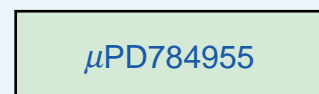

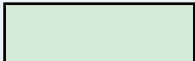
 Under development

8/16-Bit Single Chip Microcontroller

78K/0S Series

■ 78K/0S Series Products (1/12) ▶

Subseries name			μ PD789014 Subseries		
Part number			μ PD789011	μ PD789012	μ PD78P9014
Number of basic instructions			48		
Minimum instruction execution time			0.4 μ s (5.0 MHz)		
Instruction cycle			Selectable from 0.4 μ s and 1.6 μ s (5.0 MHz)		
Internal memory	ROM	Size (bytes)	2K	4K	8K (PROM)
	RAM	Size (bytes)	128		256
Address space			64K bytes		
Interrupt function		External	3		
		Internal	7		
I/O pin	CMOS I/O		22		
Timer			8-bit timer/event counter \times 2 channels Watchdog timer \times 1 channel		
Timer output			2		
Serial interface			3-wire/UART mode (selectable): 1 channel		
Standby function			STOP/HALT		
Operating power supply voltage range			$V_{DD} = 1.8$ to 5.5 V		
Package			<ul style="list-style-type: none"> • 28-pin plastic shrink DIP (400 mil) • 28-pin plastic SOP (375 mil) 		
Assembler			RA78K0S		
C compiler			CC78K0S		
Real-time OS			MX78K0S		
Device file			DF789014		
In-circuit emulator			IE-78K0S-NS + IE-789014-NS-EM1		
			NP-28CT * NP-28GT *		
Applications			Remote control, game machines, etc.		

*: This is a product of Naito Densai Machidaseisakusho Co., Ltd.

8/16-Bit Single Chip Microcontroller

78K/0S Series

■ 78K/0S Series Products (2/12) ◀▶

Subseries name			μPD789026 Subseries				
Part number			μPD789022*	μPD789024*	μPD789025	μPD789026	μPD78F9026A*
Number of basic instructions			48				
Minimum instruction execution time			0.4 μs (5.0 MHz)				
Instruction cycle			Selectable from 0.4 μs and 1.6 μs (5.0 MHz)				
Internal memory	ROM	Size (bytes)	4K	8K	12K	16K	16K (Flash memory)
	RAM	Size (bytes)	256		512		
Address space			64K bytes				
Interrupt function		External	4				
		Internal	6				
I/O pin	CMOS I/O		34				
Timer			16-bit timer counter × 1 channel 8-bit timer/event counter × 1 channel Watchdog timer × 1 channel				
Timer output			2				
Serial interface			3-wire/UART mode (selectable): 1 channel				
Standby function			STOP/HALT				
Operating power supply voltage range			V _{DD} = 1.8 to 5.5 V				
Package			<ul style="list-style-type: none"> • 42-pin plastic shrink DIP (600 mil) • 44-pin plastic QFP (10 × 10 mm) 				
Assembler			RA78K0S				
C compiler			CC78K0S				
Real-time OS			MX78K0S				
Device file			DF789026				
In-circuit emulator			IE-78K0S-NS + IE-789026-NS-EM1				
			NP-44GB * NP-42CU *				
Applications			Compact household appliances, car accessories, air-conditioners, games, etc.				

*: This is a product of Naito Densai Machidaseisakusho Co., Ltd.

*: Under development

8/16-Bit Single Chip Microcontroller

78K/0S Series

■ 78K/0S Series Products (3/12) ◀ ▶

Subseries name			μ PD789046 Subseries	
Part number			μ PD789046*	μ PD78F9046*
Number of basic instructions			48	
Minimum instruction execution time			0.4 μ s	
Instruction cycle	When main system clock is selected		Selectable from 0.4 μ s and 1.6 μ s (5.0 MHz)	
	When subsystem clock is selected		122 μ s (32.768 kHz)	
Internal memory	ROM	Size (bytes)	16K	16K (Flash memory)
	RAM	Size (bytes)	512	
Address space			64K bytes	
Interrupt function		External	4	
		Internal	8	
I/O pin	CMOS I/O		34	
Timer			16-bit timer counter \times 1 channel 8-bit timer/event counter \times 1 channel Watch timer \times 1 channel Watchdog timer \times 1 channel	
Timer output			2	
Serial interface			3-wire/UART mode (selectable): 1 channel	
Standby function			STOP/HALT	
Operating power supply voltage range			$V_{DD} = 1.8$ to 5.5 V	
Package			44-pin plastic QFP (10 \times 10 mm)	
Assembler			RA78K0S	
C compiler			CC78K0S	
Real-time OS			MX78K0S	
Device file			DF789046	
In-circuit emulator			IE-78K0S-NS + IE-789046-NS-EM1	
			NP-44GB *	
Applications			Cordless phones, etc.	

*: This is a product of Naito Densai Machidaseisakusho Co., Ltd.

*: Under development

8/16-Bit Single Chip Microcontroller

78K/0S Series

■ 78K/0S Series Products (4/12) ◀ ▶

Subseries name			μ PD789104A Subseries			μ PD789114A Subseries			
Part number			μ PD789101A*	μ PD789102A*	μ PD789104A*	μ PD789111A*	μ PD789112A*	μ PD789114A*	μ PD78F9116A*
Number of basic instructions			48						
Minimum instruction execution time			0.4 μ s (5.0 MHz)						
Instruction cycle			Selectable from 0.4 μ s and 1.6 μ s (5.0 MHz)						
System clock			Ceramic oscillator						
Internal memory	ROM	Size (bytes)	2K	4K	8K	2K	4K	8K	16K (Flash memory)
	RAM	Size (bytes)	256						
Address space			64K bytes						
Interrupt function		External	3						
		Internal	7						
Multiplier			$8 \times 8 = 16$ bits						
I/O pin	CMOS input		4						
	CMOS I/O		12						
	N-ch open-drain I/O		4						
Timer			16-bit timer counter \times 1 channel 8-bit timer/event counter \times 1 channel Watchdog timer \times 1 channel						
Timer output			2						
Serial interface			3-wire/UART mode (selectable): 1 channel						
A/D converter			8-bit resolution \times 4 channels			10-bit resolution \times 4 channels			
Standby function			STOP/HALT						
Power supply voltage range			$V_{DD} = 1.8$ to 5.5 V						
Package			<ul style="list-style-type: none"> • 28-pin plastic shrink DIP (400 mil) • 30-pin plastic shrink SOP (300 mil) 						
Assembler			RA78K0S						
C compiler			CC78K0S						
Real-time OS			MX78K0S						
Device file			DF789136						
In-circuit emulator			IE-78K0S-NS + IE-789136-NS-EM1						
			NP-28CT * NP-36GS ** + NGS-30 **						
Applications			Cleaners, washing machines, refrigerators, etc.						

*: This is a product of Naito Densai Machidaseisakusho Co., Ltd.

*: Under development

8/16-Bit Single Chip Microcontroller

78K/0S Series

■ 78K/0S Series Products (5/12) ◀▶

Subseries name			μPD789124A Subseries			μPD789134A Subseries			
Part number			μPD789121A*	μPD789122A*	μPD789124A*	μPD789131A*	μPD789132A*	μPD789134A*	μPD78F9136A*
Number of basic instructions			48						
Minimum instruction execution time			0.5 μs (4.0 MHz)						
Instruction cycle			Selectable from 0.5 μs and 2.0 μs (4.0 MHz)						
System clock			RC oscillator						
Internal memory	ROM	Size (bytes)	2K	4K	8K	2K	4K	8K	16K (Flash memory)
	RAM	Size (bytes)	256						
Address space			64K bytes						
Interrupt function		External	3						
		Internal	7						
Multiplier			8 × 8 = 16 bits						
I/O pin	CMOS input		4						
	CMOS I/O		12						
	N-ch open-drain I/O		4						
Timer			16-bit timer counter × 1 channel 8-bit timer/event counter × 1 channel Watchdog timer × 1 channel						
Timer output			2						
Serial interface			3-wire serial I/O mode/UART mode (selectable): 1 channel						
A/D converter			8-bit resolution × 4 channels			10-bit resolution × 4 channels			
Standby function			STOP/HALT						
Power supply voltage range			V _{DD} = 1.8 to 5.5 V						
Package			<ul style="list-style-type: none"> • 28-pin plastic shrink DIP (400 mil) • 30-pin plastic shrink SOP (300 mil) 						
Assembler			RA78K0S						
C compiler			CC78K0S						
Real-time OS			MX78K0S						
Device file			DF789136*						
In-circuit emulator			IE-78K0S-NS + IE-789136-NS-EM1*						
			NP-28CT* NP-36GS** + NGS-30**						
Applications			Battery chargers, etc.						

*: This is a product of Naito Densai Machidaseisakusho Co., Ltd.

★: Under development

8/16-Bit Single Chip Microcontroller

78K/0S Series

■ 78K/0S Series Products (6/12) ◀ ▶

Subseries name			μPD789146 Subseries		μPD789156 Subseries		
Part number			μPD789144*	μPD789146*	μPD789154*	μPD789156*	μPD78F9156*
Number of basic instructions			48				
Minimum instruction execution time			0.4 μs (5.0 MHz)				
Instruction cycle			Selectable from 0.4 μs and 1.6 μs (5.0 MHz)				
Internal memory	ROM	Size (bytes)	8K	16K	8K	16K	16K (Flash memory)
	RAM	Size (bytes)	256				
	EEPROM	Size (bytes)	256				
Address space			64K bytes				
Interrupt function		External	3				
		Internal	9				
Multiplier			8 × 8 = 16 bits				
I/O pin	CMOS input		4				
	CMOS I/O		12				
	N-ch open-drain I/O		4				
Timer			16-bit timer counter × 1 channel 8-bit timer/event counter × 1 channel Watchdog timer × 1 channel				
Timer output			2				
Serial interface			3-wire/UART mode (selectable): 1 channel				
A/D converter			8-bit resolution × 4 channels		10-bit resolution × 4 channels		
Low voltage indicator			Indicate a level of supply voltage				
Standby function			STOP/HALT				
Power supply voltage range			V _{DD} = 1.8 to 5.5 V				
Package			30-pin plastic shrink SOP (300 mil)				
Assembler			RA78K0S				
C compiler			CC78K0S				
Real-time OS			MX78K0S				
Device file			DF789156*				
In-circuit emulator			IE-78K0S-NS + IE-789156-NS-EM1*				
			NP-36GS ** + NGS-30**				
Applications			Side air bags, etc.				

*: This is a product of Naito Densai Machidaseisakusho Co., Ltd.

*: Under development

8/16-Bit Single Chip Microcontroller

78K/0S Series

■ 78K/0S Series Products (7/12) ◀ ▶

Subseries name			μPD789167 Subseries		μPD789177 Subseries		
Part number			μPD789166*	μPD789167*	μPD789176*	μPD789177*	μPD78F9177*
Number of basic instructions			48				
Minimum instruction execution time			0.4 μs (5.0 MHz)				
Instruction cycle	When main system clock is selected		Selectable from 0.4 μs and 1.6 μs (5.0 MHz)				
	When subsystem clock is selected		122 μs (32.768 kHz)				
System clock			Ceramic oscillator				
Internal memory	ROM	Size (bytes)	16K	24K	16K	24K	24K (Flash memory)
	RAM	Size (bytes)	512				
Address space			64K bytes				
Interrupt function	External		4				
	Internal		11				
Multiplier			8 × 8 = 16 bits				
I/O pin	CMOS input		8				
	CMOS I/O		17				
	N-ch open-drain I/O		6				
Timer			16-bit timer counter × 1 channel 8-bit timer counter × 1 channel 8-bit timer/event counter × 2 channels Watch timer × 1 channel Watchdog timer × 1 channel				
Timer output			4				
Serial interface			3-wire/UART mode (selectable): 1 channel				
A/D converter			8-bit resolution × 8 channels		10-bit resolution × 8 channels		
Standby function			STOP/HALT				
Power supply voltage range			V _{DD} = 1.8 to 5.5 V				
Package			44-pin plastic QFP (10 × 10 mm)				
Assembler			RA78K0S				
C compiler			CC78K0S				
Real-time OS			MX78K0S				
Device file			DF789197*				
In-circuit emulator			IE-78K0S-NS + IE-789197-NS-EM1*				
			NP-44GB *				
Applications			Power windows, keyless entries, battery management units, side air bags, etc.				

*: This is a product of Naito Densai Machidaseisakusho Co., Ltd.

*: Under development

8/16-Bit Single Chip Microcontroller

78K/0S Series

■ 78K/0S Series Products (8/12) ◀▶

Subseries name		μPD789197AY Subseries		
Part number		μPD789196AY*	μPD789197AY*	μPD78F9197AY*
Number of basic instructions		48		
Minimum instruction execution time		0.4 μs (5.0 MHz)		
Instruction cycle	When main system clock is selected	Selectable from 0.4 μs and 1.6 μs (5.0 MHz)		
	When subsystem clock is selected	122 μs (32.768 kHz)		
System clock		Ceramic oscillator		
Internal memory	ROM	Size (bytes)	16K	24K
	RAM	Size (bytes)	512	
	EEPROM	Size (bytes)	128	
Address space		64K bytes		
Interrupt function	External	4		
	Internal	15		
Multiplier		8 × 8 = 16 bits		
I/O pin	CMOS input	8		
	CMOS I/O	17		
	N-ch open-drain I/O	6		
Timer		16-bit timer counter × 1 channel 8-bit timer counter × 1 channel 8-bit timer/event counter × 2 channels Watch timer × 1 channel Watchdog timer × 1 channel		
Timer output		4		
Serial interface		3-wire/UART mode (selectable): 1 channel SMB: 1 channel		
A/D converter		10-bit resolution × 8 channels		
Low voltage indicator		Indicate a level of supply voltage		
Standby function		STOP/HALT		
Power supply voltage range		V _{DD} = 1.8 to 5.5 V		
Package		<ul style="list-style-type: none"> • 44-pin plastic QFP (10 × 10 mm) • 48-pin plastic TQFP (fine pitch) (7 × 7 mm) 		
Assembler		RA78K0S		
C compiler		CC78K0S		
Real-time OS		MX78K0S		
Device file		DF789197*		
In-circuit emulator	IE-78K0S-NS + IE-789197-NS-EM1*			
	NP-44GB * NP-48GA *			
Applications		Battery management units, etc.		

*: This is a product of Naito Densai Machidaseisakusho Co., Ltd.

*: Under development

8/16-Bit Single Chip Microcontroller

78K/0S Series

■ 78K/0S Series Products (9/12) ◀ ▶

Subseries name		μPD789217AY Subseries			
Part number		μPD789216AY*	μPD789217AY*	μPD78F9217AY*	
Number of basic instructions		48			
Minimum instruction execution time		0.4 μs (5.0 MHz)			
Instruction cycle	When main system clock is selected	Selectable from 0.5 μs and 2.0 μs (4.0 MHz)			
	When subsystem clock is selected	122 μs (32.768 kHz)			
System clock		RC oscillator			
Internal memory	ROM	Size (bytes)	16K	24K	32K
	RAM	Size (bytes)	512		
	EEPROM	Size (bytes)	128		
Address space		64K bytes			
Interrupt function	External	4			
	Internal	15			
Multiplier		8 × 8 = 16 bits			
I/O pin	CMOS input	8			
	CMOS I/O	17			
	N-ch open-drain I/O	6			
Timer		16-bit timer counter × 1 channel 8-bit timer counter × 1 channel 8-bit timer/event counter × 2 channels Watch timer × 1 channel Watchdog timer × 1 channel			
Timer output		4			
Serial interface		3-wire/UART mode (selectable): 1 channel SMB: 1 channel			
A/D converter		10-bit resolution × 8 channels			
Low voltage indicator		Indicate a level of supply voltage			
Standby function		STOP/HALT			
Power supply voltage range		V _{DD} = 1.8 to 5.5 V			
Package		<ul style="list-style-type: none"> • 44-pin plastic QFP (10 × 10 mm) • 48-pin plastic TQFP (fine pitch) (7 × 7 mm) 			
Assembler		RA78K0S			
C compiler		CC78K0S			
Real-time OS		MX78K0S			
Device file		DF789197*			
In-circuit emulator	IE-78K0S-NS + IE-789197-NS-EM1*				
	NP-44GB * NP-48GA *				
Applications		Battery management units, etc.			

*: This is a product of Naito Densai Machidaseisakusho Co., Ltd.

*: Under development

8/16-Bit Single Chip Microcontroller

78K/0S Series

■ 78K/0S Series Products (10/12) ◀ ▶

Subseries name			μPD789407A Subseries			μPD789417A Subseries			
Part number			μPD789405A*	μPD789406A*	μPD789407A*	μPD789415A*	μPD789416A*	μPD789417A*	μPD78F9418A*
Number of basic instructions			48						
Minimum instruction execution time			0.4 μs (5.0 MHz)						
Instruction cycle	When main system clock is selected		Selectable from 0.4 μs and 1.6 μs (5.0 MHz)						
	When subsystem clock is selected		122 μs (32.768 kHz)						
Internal memory	ROM	Size (bytes)	12K	16K	24K	12K	16K	24K	32K (Flash memory)
	RAM	Size (bytes)	512						
	LCD data RAM	Size (bytes)	28						
Address space			64K bytes						
Interrupt function		External	5						
		Internal	12						
I/O pin	CMOS input		7						
	CMOS I/O		32						
	N-ch open-drain I/O		4						
Timer			16-bit timer counter × 1 channel 8-bit timer counter × 1 channel 8-bit timer/event counter × 2 channels Watch timer × 1 channel Watchdog timer × 1 channel						
Timer output			2						
Serial interface			3-wire/UART mode (selectable): 1 channel						
A/D converter			8-bit resolution × 7 channels			10-bit resolution × 7 channels			
LCD controller/driver			Number of segment signal outputs: 28 maximum Number of common signal outputs: 4 maximum Bias: 1/2 or 1/3 (switchable)						
Standby function			STOP/HALT						
Power supply voltage range			V _{DD} = 1.8 to 5.5 V						
Package			<ul style="list-style-type: none"> • 80-pin plastic QFP (14 × 14 mm) • 80-pin plastic TQFP (fine pitch) (12 × 12 mm) 						
Assembler			RA78K0S						
C compiler			CC78K0S						
Real-time OS			MX78K0S						
Device file			DF789418						
In-circuit emulator			IE-78K0S-NS + IE-789418-NS-EM1						
			NP-80GC * NP-80GK *						
Applications			APS compact cameras, etc.						

*: This is a product of Naito Densai Machidaseisakusho Co., Ltd.

★: Under development

8/16-Bit Single Chip Microcontroller

78K/0S Series

■ 78K/0S Series Products (11/12) ◀ ▶

Subseries name			μ PD789800 Subseries	
Part number			μ PD789800	μ PD78F9801*
Number of basic instructions			48	
Minimum instruction execution time			0.33 μ s (6.0 MHz)	
Instruction cycle			Selectable from 0.33 μ s and 1.33 μ s (6.0 MHz)	
Internal memory	ROM	Size (bytes)	8K	16K (Flash memory)
	RAM	Size (bytes)	256	
Address space			64K bytes	
Interrupt function		External	2	
		Internal	10	
I/O pin	CMOS I/O		31 (18 ports of the above CMOS I/O ports can be switched to N-ch open-drain I/O ports)	
Timer			8-bit timer \times 1 channel 8-bit timer/event counter \times 1 channel Watchdog timer \times 1 channel	
Serial interface			USB (Universal Serial Bus): 1 channel 3-wire: 1 channel	
Regulator			Incorporated ($V_{REG} = 3.3 \pm 0.3$ V)	
Standby function			STOP/HALT	
Power supply voltage range			$V_{DD} = 4.0$ to 5.5 V	
Operating ambient temperature			$T_A = -40$ to $+85^\circ\text{C}$ (When the USB is not operating) $T_A = 0$ to 70°C (When the USB is operating)	
Package			<ul style="list-style-type: none"> • 42-pin plastic shrink DIP (600 mil) • 44-pin plastic QFP (10 \times 10 mm) 	
Assembler			RA78K0S	
C compiler			CC78K0S	
Real-time OS			MX78K0S	
Device file			DF789801	
In-circuit emulator			IE-78K0S-NS + IE-789801-NS-EM1	
			NP-42CU * NP-44GB *	
Applications			USB keyboards, etc.	

*: This is a product of Naito Densai Machidaseisakusho Co., Ltd.

*: Under development

8/16-Bit Single Chip Microcontroller

78K/0S Series

■ 78K/0S Series Products (12/12) ◀

Subseries name		μPD789830 Subseries	
Part number		μPD789830*	μPD78F9831*
Number of basic instructions		48	
Minimum instruction execution time		0.4 μs	
Instruction cycle	When main system clock is selected	Selectable from 0.4 μs and 1.6 μs (5.0 MHz)	
	When subsystem clock is selected	122 μs (32.768 kHz)	
Internal memory	ROM	Size (bytes)	24K
	RAM	Size (bytes)	1024
	LCD data RAM	Size (bytes)	80
Address space		64K bytes	
Interrupt function	External	3	5
	Internal	11	
I/O pin	CMOS I/O	30	38
Timer		16-bit timer counter × 1 channel 8-bit timer counter × 1 channel Watch timer × 1 channel Watchdog timer × 1 channel	
Timer output		2	
Serial interface		UART: 1 channel	
LCD controller/driver		Segment signal output: 40 maximum Common signal output: 16 maximum	
Standby function		STOP/HALT	
Operating power supply voltage range		V _{DD} = 2.7 to 5.5 V	
Delivery form		88-pin bare chip	100-pin plastic LQFP (14 × 14 mm)
Assembler		RA78K0S	
C compiler		CC78K0S	
Real-time OS		MX78K0S	
Device file		DF789831	
In-circuit emulator		IE-78K0S-NS + IE-789831-NS-EM1	
		NP-100GC *	
Applications		Card readers, etc.	

*: This is a product of Naito Densai Machidaseisakusho Co., Ltd.

★: Under development

8/16-Bit Single Chip Microcontroller

78K/0 Series

■ 78K/0 Series Products (1/32) ▶

Subseries name			μPD78018F Subseries							
Part number			μPD78011F	μPD78012F	μPD78013F	μPD78014F	μPD78015F	μPD78016F	μPD78018F	μPD78P018F
Number of basic instructions			63							
Minimum instruction execution time			0.4 μs (10.0 MHz)							
Instruction cycle	When main system clock is selected		Selectable from 0.4 μs, 0.8 μs, 1.6 μs, 3.2 μs, and 6.4 μs (10.0 MHz)							
	When subsystem clock is selected		122 μs (32.768 kHz)							
Internal memory	ROM	Size (bytes)	8K	16K	24K	32K	40K	48K	60K	60K (PROM)
	RAM	Size (bytes)	544		1056		1568		2080	
Address space			64K bytes							
Interrupt function	External		4							
	Internal		10							
I/O pin	CMOS input		2							
	CMOS I/O		47							
	N-ch open-drain I/O		4							
Timer			16-bit timer/event counter × 1 channel 8-bit timer/event counter × 2 channels Clock timer × 1 channel Watchdog timer × 1 channel							
Timer output			3 (PWM output: 1)							
Serial interface			3-wire/SBI/2-wire mode (selectable): 1 channel 3-wire (with function for automatic transmission and reception of up to 32 bytes): 1 channel							
A/D converter			8-bit resolution × 8 channels							
Others			Clock output function Buzzer output function							
Standby function			STOP/HALT							
Operating power supply voltage range			1.8 to 5.5 V							
Package			<ul style="list-style-type: none"> • 64-pin plastic shrink DIP (750 mil) • 64-pin plastic QFP (14 × 14 mm, 0.8-mm pitch) • 64-pin plastic QFP (12 × 12 mm, 0.65-mm pitch) 							*1
Assembler			RA78K0							
C compiler			CC78K0							
Real-time OS			MX78K0		RX78K0, MX78K0					
Integrated debugger			ID78K0 or ID78K0-NS							
			DF78014							
In-circuit emulator			IE-78001-R-A (with ID78K0), IE-78K0-NS (with ID78K0-NS)							
			With IE-78001-R-A: IE-78014-R-EM-A, with IE-78K0-NS: IE-78018-NS-EM1							
			With IE-78001-R-A: EP-78240CW-R, EP-78240GC-R, EP-78012GK-R With IE-78K0-NS: NP-64CW *2, NP-64GC *2, NP-64GK *2							
Applications			VCRs, TVs, audio equipments, etc.							

- *1: • 64-pin plastic shrink DIP (750 mil)
• 64-pin plastic QFP (14 × 14 mm, 0.8-mm pitch)
• 64-pin plastic QFP (12 × 12 mm, 0.65-mm pitch)
• 64-pin ceramic shrink DIP with window (750 mil)
• 64-pin ceramic WQFN (14 × 14 mm)

*2: This is a product of Naito Densai Machidaseisakusho Co., Ltd.

8/16-Bit Single Chip Microcontroller

78K/0 Series

■ 78K/0 Series Products (2/32) ◀ ▶

Subseries name		μPD78018FY Subseries									
Part number		μPD78011FY	μPD78012FY	μPD78013FY	μPD78014FY	μPD78015FY	μPD78016FY	μPD78018FY	μPD78P018FY		
Number of basic instructions		63									
Minimum instruction execution time		0.4 μs (10.0 MHz)									
Instruction cycle	When main system clock is selected	Selectable from 0.4 μs, 0.8 μs, 1.6 μs, 3.2 μs, and 6.4 μs (10.0 MHz)									
	When subsystem clock is selected	122 μs (32.768 kHz)									
Internal memory	ROM	Size (bytes)	8K	16K	24K	32K	40K	48K	60K	60K (PROM)	
	RAM	Size (bytes)	544		1056		1568		2080		
Address space		64K bytes									
Interrupt function	External	4									
	Internal	10									
I/O pin	CMOS input		2								
	CMOS I/O		47								
	N-ch open-drain I/O		4								
Timer		16-bit timer/event counter × 1 channel 8-bit timer/event counter × 2 channels Clock timer × 1 channel Watchdog timer × 1 channel									
Timer output		3 (PWM output: 1)									
Serial interface		3-wire/2-wire/I ² C bus mode (selectable): 1 channel 3-wire (with function for automatic transmission and reception of up to 32 bytes): 1 channel									
A/D converter		8-bit resolution × 8 channels									
Others		Clock output function Buzzer output function									
Standby function		STOP/HALT									
Operating power supply voltage range		1.8 to 5.5 V									
Package		<ul style="list-style-type: none"> • 64-pin plastic shrink DIP (750 mil) • 64-pin plastic QFP (14 × 14 mm, 0.8-mm pitch) • 64-pin plastic QFP (12 × 12 mm, 0.65-mm pitch) (except μPD78013FY, 78015FY, 78016FY, 78018FY)								*1	
Assembler		RA78K0									
C compiler		CC78K0									
Real-time OS		MX78K0			RX78K0, MX78K0						
Integrated debugger		ID78K0 or ID78K0-NS									
		DF78014									
In-circuit emulator		IE-78001-R-A (with ID78K0), IE-78K0-NS (with ID78K0-NS)									
		With IE-78001-R-A: IE-78014-R-EM-A, with IE-78K0-NS: IE-78018-NS-EM1									
		With IE-78001-R-A: EP-78240CW-R, EP-78240GC-R, EP-78012GK-R With IE-78K0-NS: NP-64CW ^{*2} , NP-64GC ^{*2} , NP-64GK ^{*2}									
Applications		VCRs, TVs, audio equipments, etc.									

- *1: • 64-pin plastic shrink DIP (750 mil)
 • 64-pin plastic QFP (14 × 14 mm, 0.8-mm pitch)
 • 64-pin plastic QFP (12 × 12 mm, 0.65-mm pitch)
 • 64-pin ceramic shrink DIP with window (750 mil)
 • 64-pin ceramic WQFN (14 × 14 mm)

*2: This is a product of Naito Densai Machidaseisakusho Co., Ltd.

8/16-Bit Single Chip Microcontroller

78K/0 Series

■ 78K/0 Series Products (3/32) ◀ ▶

Subseries name		μPD78014H Subseries				
Part number		μPD78011H	μPD78012H	μPD78013H	μPD78014H	
Number of basic instructions		63				
Minimum instruction execution time		0.4 μs (10.0 MHz)				
Instruction cycle	When main system clock is selected	Selectable from 0.4 μs, 0.8 μs, 1.6 μs, 3.2 μs, and 6.4 μs (10.0 MHz)				
	When subsystem clock is selected	122 μs (32.768 kHz)				
Internal memory	ROM	Size (bytes)	8K	16K	24K	32K
	RAM	Size (bytes)	544		1056	
Address space		64K bytes				
Interrupt function	External	4				
	Internal	10				
I/O pin	CMOS input	2				
	CMOS I/O	47				
	N-ch open-drain I/O	4				
Timer		16-bit timer/event counter × 1 channel 8-bit timer/event counter × 2 channels Clock timer × 1 channel Watchdog timer × 1 channel				
Timer output		3 (PWM output: 1)				
Serial interface		3-wire/SBI/2-wire mode (selectable): 1 channel 3-wire (with function for automatic transmission and reception of up to 32 bytes): 1 channel				
A/D converter		8-bit resolution × 8 channels				
Others		Clock output function Buzzer output function				
Standby function		STOP/HALT				
Operating power supply voltage range		1.8 to 5.5 V				
Package		<ul style="list-style-type: none"> • 64-pin plastic shrink DIP (750 mil) • 64-pin plastic QFP (14 × 14 mm, 0.8-mm pitch) • 64-pin plastic QFP (12 × 12 mm, 0.65-mm pitch) 				
Assembler		RA78K0				
C compiler		CC78K0				
Real-time OS		MX78K0	RX78K0, MX78K0			
Integrated debugger		ID78K0 or ID78K0-NS				
		DF78014				
In-circuit emulator		IE-78001-R-A (with ID78K0), IE-78K0-NS (with ID78K0-NS)				
		With IE-78001-R-A: IE-78014-R-EM-A, IE-78K0-NS: IE-78018-NS-EM1				
		With IE-78001-R-A: EP-78240CW-R, EP-78240GC-R, EP-78012GK-R With IE-78K0-NS: NP-64CW *, NP-64GC *, NP-64GK *				
Applications		Cellular phones, VCRs, audio equipments, cameras, home appliances, etc.				

*: This is a product of Naito Densai Machidaseisakusho Co., Ltd.

8/16-Bit Single Chip Microcontroller

78K/0 Series

■ 78K/0 Series Products (4/32) ◀ ▶

Subseries name		μ PD780024 Subseries μ PD780034 Subseries				
Part number		μ PD780021* μ PD780031*	μ PD780022* μ PD780032*	μ PD780023* μ PD780033*	μ PD780024* μ PD780034*	μ PD78F0034*
Number of basic instructions		63				
Minimum instruction execution time		0.24 μ s (8.38 MHz)				
Instruction cycle	When main system clock is selected	Selectable from 0.24 μ s, 0.48 μ s, 0.95 μ s, 1.91 μ s, and 3.81 μ s (8.38 MHz)				
	When subsystem clock is selected	122 μ s (32.768 kHz)				
Internal memory	ROM	Size (bytes)	8K	16K	24K	32K
	RAM	Size (bytes)	512		1024	
Address space		64K bytes				
Interrupt function	External	5				
	Internal	15				
I/O pin	CMOS input		8			
	CMOS I/O		39			
	N-ch open-drain I/O		4			
Timer		16-bit timer/event counter \times 1 channel 8-bit timer/event counter \times 2 channels Clock timer \times 1 channel Watchdog timer \times 1 channel				
Timer output		3 (PWM output: 2)				
Serial interface		3-wire: 2 channels UART: 1 channel				
A/D converter		8-bit resolution \times 8 channels (μ PD780021, 780022, 780023, 780024) 10-bit resolution \times 8 channels (μ PD780031, 780032, 780033, 780034, 78F0034)				
Others		Clock output function Buzzer output function				
Standby function		STOP/HALT				
Operating power supply voltage range		1.8 to 5.5 V				
Package		<ul style="list-style-type: none"> • 64-pin plastic shirink DIP (750 mil) • 64-pin plastic QFP (14 \times 14 mm, 0.8-mm pitch) • 64-pin plastic QFP (12 \times 12 mm, 0.65-mm pitch) 				
Assembler		RA78K0				
C compiler		CC78K0				
Real-time OS		RX78K0, MX78K0				
Integrated debugger		ID78K0 or ID78K0-NS DF780024, DF780034				
In-circuit emulator		IE-78001-R-A (with ID78K0), IE-78K0-NS (with ID78K0-NS) With IE-78001-R-A: IE-78K0-SL-P01, IE-780034-SL-EM4 With IE-78K0-NS: IE-780034-NS-EM1 With IE-78001-R-A: EP-78240CW-R, EP-78240GC-R, EP-78012GK-R With IE-78K0-NS: NP-64CW *, NP-64GC *, NP-64GK *				
Applications		VCRs, TVs, audio equipments, etc.				

*: This is a product of Naito Densai Machidaseisakusho Co., Ltd.

*: Under development

8/16-Bit Single Chip Microcontroller

78K/0 Series

■ 78K/0 Series Products (5/32) ◀ ▶

Subseries name		μPD780024Y Subseries μPD780034Y Subseries					
Part number		μPD780021Y*	μPD780022Y*	μPD780023Y*	μPD780024Y*	μPD780034Y*	μPD78F0034Y*
Number of basic instructions		63					
Minimum instruction execution time		0.24 μs (8.38 MHz)					
Instruction cycle	When main system clock is selected	Selectable from 0.24 μs, 0.48 μs, 0.95 μs, 1.91 μs, and 3.81 μs (8.38 MHz)					
	When subsystem clock is selected	122 μs (32.768 kHz)					
Internal memory	ROM	Size (bytes)	8K	16K	24K	32K	32K (Flash memory)
	RAM	Size (bytes)	512			1024	
Address space		64K bytes					
Interrupt function	External	5					
	Internal	15					
I/O pin	CMOS input		8				
	CMOS I/O		39				
	N-ch open-drain I/O		4				
Timer		16-bit timer/event counter × 1 channel 8-bit timer/event counter × 2 channels Clock timer × 1 channel Watchdog timer × 1 channel					
Timer output		3 (PWM output: 2)					
Serial interface		3-wire: 1 channel UART: 1 channel I ² C bus (supporting multi-master): 1 channel					
A/D converter		8-bit resolution × 8 channels (μPD780021Y, 780022Y, 780023Y, 780024Y) 10-bit resolution × 8 channels (μPD780031Y, 780032Y, 780033Y, 780034Y, 78F0034Y)					
Others		Clock output function Buzzer output function					
Standby function		STOP/HALT					
Operating power supply voltage range		1.8 to 5.5 V					
Package		<ul style="list-style-type: none"> • 64-pin plastic shirink DIP (750 mil) • 64-pin plastic QFP (14 × 14 mm, 0.8-mm pitch) • 64-pin plastic QFP (12 × 12 mm, 0.65-mm pitch) 					
Assembler		RA78K0					
C compiler		CC78K0					
Real-time OS		RX78K0, MX78K0					
Integrated debugger		ID78K0 or ID78K0-NS					
		DF780024, DF780034					
In-circuit emulator		IE-78001-R-A (with ID78K0), IE-78K0-NS (with ID78K0-NS)					
		With IE-78001-R-A: IE-78K0-SL-P01, IE-780034-SL-EM4 With IE-78K0-NS: IE-780034-NS-EM1					
		With IE-78001-R-A: EP-78240CW-R, EP-78240GC-R, EP-78012GK-R With IE-78K0-NS: NP-64CW *, NP-64GC *, NP-64GK *					
Applications		VCRs, TVs, audio equipments, etc.					

*: This is a product of Naito Densai Machidaseisakusho Co., Ltd.

*: Under development

8/16-Bit Single Chip Microcontroller

78K/0 Series

■ 78K/0 Series Products (6/32) ◀ ▶

Subseries name		μ PD780065 Subseries	
Part number		μ PD780065*	μ PD78F0066*
Number of basic instructions		63	
Minimum instruction execution time		0.24 μ s (8.38 MHz)	
Instruction cycle	When main system clock is selected	Selectable from 0.24 μ s, 0.48 μ s, 0.96 μ s, 1.92 μ s, 3.84 μ s and 7.68 μ s (8.38 MHz)	
	When subsystem clock is selected	122 μ s (32.768 kHz)	
Internal memory	ROM	40K	48K (Flash memory)
	RAM	5K	
Address space		64K bytes	
Interrupt function	External	4	
	Internal	13	
I/O pin	CMOS I/O	53	
Timer		16-bit timer/event counter \times 1 channel 8-bit timer \times 2 channels Watch timer \times 1 channel Watchdog timer \times 1 channel	
Timer output		3 (PWM output: 2)	
Serial interface		3-wire/2-wire mode (selectable): 1 channel 3-wire (with function for automatic transmission and reception of up to 32 bytes): 1 channel UART: 1 channel	
A/D converter		8-bit resolution \times 8 channels	
Others		Clock output function Buzzer output function	
Standby function		STOP/HALT	
Operating power supply voltage range		$V_{DD} = 2.7$ to 5.5 V	
Package		80-pin plastic QFP (14 \times 14 mm, 0.65-mm pitch)	
Assembler		RA78K0	
C compiler		CC78K0	
Real-time OS		RX78K0, MX78K0	
Integrated debugger		ID78K0-NS	
		DF780065	
In-circuit emulator		IE-78001-R-A or IE-78K0-NS	
		IE-78K0-NS-P01 + IE-780066-NS-EM4	
		With IE-78001-R-A: EP-78230GC-R + IE-78K0-R-EX1 With IE-78K0-NS: NP-80GC *	
Applications		Control of audio systems compatible with CD text, etc.	

*: This is a product of Naito Densai Machidaseisakusho Co., Ltd.

*: Under development

8/16-Bit Single Chip Microcontroller

78K/0 Series

■ 78K/0 Series Products (7/32) ◀ ▶

Subseries name		μPD780018AY Subseries		
Part number		μPD780016AY	μPD780018AY	μPD78P0018AY*
Number of basic instructions		63		
Minimum instruction execution time		0.4 μs (5.0 MHz)		
Instruction cycle	When main system clock is selected	Selectable from 0.4 μs, 0.8 μs, 1.6 μs, 3.2 μs, and 6.4 μs (5.0 MHz)		
	When subsystem clock is selected	122 μs (32.768 kHz)		
Internal memory	ROM	Size (bytes)	48K	60K
	RAM	Size (bytes)	2080	
Address space		64K bytes		
Interrupt function	External	7		
	Internal	13		
I/O pin	CMOS input	9		
	CMOS I/O	79		
Timer		16-bit timer/event counter × 1 channel 8-bit timer/event counter × 4 channels Clock timer × 1 channel Watchdog timer × 1 channel		
Timer output		5 (PWM output: 3)		
Serial interface		3-wire (with function for automatic transmission and reception of up to 32 bytes): 1 channel 3-wire (with time-division transmission function): 1 channel I ² C bus (supporting multi-master): 1 channel		
A/D converter		8-bit resolution × 8 channels		
Others		Clock output function Buzzer output function		
Standby function		Main STOP/Sub STOP/HALT		
Operating power supply voltage range		2.7 to 5.5 V		
Package		• 100-pin plastic QFP (14 × 20 mm, 0.65-mm pitch)	*1	
Assembler		RA78K0		
C compiler		CC78K0		
Real-time OS		RX78K0, MX78K0		
Integrated debugger		ID78K0 or ID78K0-NS		
		DF780018		
In-circuit emulator		IE-78001-R-A (with ID78K0), IE-78K0-NS (with ID78K0-NS)		
		With IE-78001-R-A: IE-780018-R-EM, with IE-78K0-NS: IE-780018-NS-EM1		
		With IE-78001-R-A: EP-78064GF-R, with IE-78K0-NS: NP-100GF *2		
Applications		Mini-component stereo systems, car stereos, etc.		

*1: • 100-pin plastic QFP (14 × 20 mm, 0.65-mm pitch)
• 100-pin ceramic WQFN (14 × 20 mm)

*: Under development

*2: This is a product of Naito Densai Machidaseisakusho Co., Ltd.

8/16-Bit Single Chip Microcontroller

78K/0 Series

■ 78K/0 Series Products (8/32) ◀ ▶

Subseries name		μPD78044F Subseries					
Part number		μPD78042F	μPD78043F	μPD78044F	μPD78045F	μPD78P048A	
Number of basic instructions		63					
Minimum instruction execution time		0.4 μs (5.0 MHz)					
Instruction cycle	When main system clock is selected	Selectable from 0.4 μs, 0.8 μs, 1.6 μs, 3.2 μs, and 6.4 μs (5.0 MHz)					
	When subsystem clock is selected	122 μs (32.768 kHz)					
Internal memory	ROM	Size (bytes)	16K	24K	32K	40K	60K (PROM)
	RAM	Size (bytes)	624		1136		
Interrupt function		External	4				
		Internal	12				
I/O pin	CMOS input		2				
	CMOS I/O		27				
	N-ch open-drain I/O		5				
	P-ch open-drain I/O		16				
	P-ch open-drain output		18				
Timer		16-bit timer/event counter × 1 channel 8-bit timer/event counter × 2 channels Clock timer × 1 channel Watchdog timer × 1 channel 6-bit up/down counter × 1 channel					
Timer output		3 (PWM output: 1)					
Serial interface		3-wire/SBI/2-wire mode (selectable): 1 channel 3-wire (with function for automatic transmission and reception of up to 64 bytes): 1 channel					
A/D converter		8-bit resolution × 8 channels					
FIP controller/driver		Number of segments: 9 to 24 Number of digits: 2 to 16					
Others		Clock output function Buzzer output function					
Standby function		STOP/HALT					
Operating power supply voltage range		2.7 to 5.5 V					
Package		• 80-pin plastic QFP (14 × 20 mm, 0.8-mm pitch)				*1	
Assembler		RA78K0					
C compiler		CC78K0					
Real-time OS		MX78K0		RX78K0, MX78K0			
Integrated debugger		ID78K0 or ID78K0-NS					
		DF78044					
In-circuit emulator		IE-78001-R-A (with ID78K0), IE-78K0-NS (with ID78K0-NS)					
		With IE-78001-R-A: IE-78044-R-EM, with IE-78K0-NS: IE-78048-NS-EM1					
		With IE-78001-R-A: EP-78130GF-R, with IE-78K0-NS: NP-80GF *2					
Applications		VCRs, audio equipments, microwave ovens, etc.					

*1: • 80-pin plastic QFP (14 × 20 mm, 0.8-mm pitch)

• 80-pin ceramic WQFN (14 × 20 mm)

*2: This is a product of Naito Densai Machidaseisakusho Co., Ltd.

8/16-Bit Single Chip Microcontroller

78K/0 Series

■ 78K/0 Series Products (9/32) ◀ ▶

Subseries name		μ PD78044H Subseries			
Part number		μ PD78044H	μ PD78045H	μ PD78046H	
Number of basic instructions		63			
Minimum instruction execution time		0.4 μ s (5.0 MHz)			
Instruction cycle	When main system clock is selected	Selectable from 0.4 μ s, 0.8 μ s, 1.6 μ s, 3.2 μ s, and 6.4 μ s (5.0 MHz)			
	When subsystem clock is selected	122 μ s (32.768 kHz)			
Internal memory	ROM	Size (bytes)	32K	40K	48K
	RAM	Size (bytes)	1136		
Interrupt function	External		4		
	Internal		10		
I/O pin	CMOS input		2		
	CMOS I/O		19		
	N-ch open-drain I/O		13		
	P-ch open-drain I/O		16		
P-ch open-drain output		18			
Timer		16-bit timer/event counter \times 1 channel 8-bit timer/event counter \times 2 channels Clock timer \times 1 channel Watchdog timer \times 1 channel			
Timer output		3 (PWM output: 1)			
Serial interface		3-wire: 1 channel			
A/D converter		8-bit resolution \times 8 channels			
FIP controller/driver		Number of segments: 9 to 24 Number of digits: 2 to 16			
Others		Clock output function Buzzer output function			
Standby function		STOP/HALT			
Operating power supply voltage range		2.7 to 5.5 V			
Package		• 80-pin plastic QFP (14 \times 20 mm, 0.8-mm pitch)		*1	
Assembler		RA78K0			
C compiler		CC78K0			
Real-time OS		RX78K0, MX78K0			
Integrated debugger		ID78K0 or ID78K0-NS			
		DF78044			
In-circuit emulator		IE-78001-R-A (with ID78K0), IE-78K0-NS(with ID78K0-NS)			
		With IE-78001-R-A: IE-78044-R-EM, with IE-78K0-NS: IE-78048-NS-EM1			
		With IE-78001-R-A: EP-78130GF-R, with IE-78K0-NS: NP-80GF *2			
Applications		Mini-component stereo systems, microwave ovens, ECRs, etc.			

*1: • 80-pin plastic QFP (14 \times 20 mm, 0.8-mm pitch)

• 80-pin ceramic WQFN (14 \times 20 mm)

*2: This is a product of Naito Densai Machidaseisakusho Co., Ltd.

8/16-Bit Single Chip Microcontroller

78K/0 Series

■ 78K/0 Series Products (10/32) ◀▶

Subseries name		μPD780208 Subseries				
Part number		μPD780204	μPD780205	μPD780206	μPD780208	μPD78P0208
Number of basic instructions		63				
Minimum instruction execution time		0.4 μs (5.0 MHz)				
Instruction cycle	When main system clock is selected	Selectable from 0.4 μs, 0.8 μs, 1.6 μs, 3.2 μs, and 6.4 μs (5.0 MHz)				
	When subsystem clock is selected	122 μs (32.768 kHz)				
Internal memory	ROM	Size (bytes)	32K	40K	48K	60K
	RAM	Size (bytes)	1168		2192	
Interrupt function	External	4				
	Internal	12				
I/O pin	CMOS input	2				
	CMOS I/O	27				
	N-ch open-drain I/O	5				
	P-ch open-drain I/O	24				
	P-ch open-drain output	16				
Timer	16-bit timer/event counter × 1 channel 8-bit timer/event counter × 2 channels Clock timer × 1 channel Watchdog timer × 1 channel					
Timer output	3 (PWM output: 1)					
Serial interface	3-wire/SBI/2-wire mode (selectable): 1 channel 3-wire (with function for automatic transmission and reception of up to 64 bytes): 1 channel					
A/D converter	8-bit resolution × 8 channels					
FIP controller/driver	Number of segments: 9 to 40 Number of digits: 2 to 16					
Others	Clock output function Buzzer output function					
Standby function	STOP/HALT					
Operating power supply voltage range	2.7 to 5.5 V					
Package	• 100-pin plastic QFP (14 × 20 mm, 0.65-mm pitch)				*1	
Assembler	RA78K0					
C compiler	CC78K0					
Real-time OS	RX78K0, MX78K0					
Integrated debugger	ID78K0 or ID78K0-NS					
	DF780208					
In-circuit emulator	IE-78001-R-A (with ID78K0), IE-78K0-NS (with ID78K0-NS)					
	With IE-78001-R-A: IE-780208-R-EM, with IE-78K0-NS: IE-780208-NS-EM1					
	With IE-78001-R-A: EP-78064GF-R, with IE-78K0-NS: NP-100GF *2					
Applications	VCRs, audio equipments, microwave ovens, etc.					

*1: • 100-pin plastic QFP (14 × 20 mm, 0.65-mm pitch)

• 100-pin ceramic WQFN (14 × 20 mm)

*2: This is a product of Naito Densai Machidaseisakusho Co., Ltd.

8/16-Bit Single Chip Microcontroller

78K/0 Series

■ 78K/0 Series Products (11/32) ◀ ▶

Subseries name			μ PD780228 Subseries	
Part number			μ PD780226	μ PD780228
Number of basic instructions			63	
Minimum instruction execution time			0.4 μ s (5.0 MHz)	
Instruction cycle			Selectable from 0.4 μ s, 0.8 μ s, 1.6 μ s, 3.2 μ s, and 6.4 μ s (5.0 MHz)	
Internal memory	ROM	Size (bytes)	48K	60K
	RAM	Size (bytes)	2192	
Interrupt function		External	4	
		Internal	8	
I/O pin	CMOS input		8	
	CMOS I/O		16	
	N-ch open-drain I/O		16	
	P-ch open-drain I/O		24	
	P-ch open-drain output		8	
Timer			8-bit remote control timer \times 1 channel 8-bit PWM timer \times 2 channels Watchdog timer \times 1 channel	
Serial interface			3-wire: 1 channel	
A/D converter			8-bit resolution \times 8 channels	
FIP controller/driver			Number of Display outputs: 48	
Standby function			STOP/HALT	
Operating power supply voltage range			4.5 to 5.5 V	
Package			• 100-pin plastic QFP (14 \times 20 mm, 0.65-mm pitch)	
Assembler			RA78K0	
C compiler			CC78K0	
Real-time OS			RX78K0, MX78K0	
Integrated debugger			ID78K0	
			DF780228	
In-circuit emulator			IE-78001-R-A	
			IE-78K0-SL-P01, IE-780228-SL-EM4	
			EP-78064GF-R	
Applications			Combined mini-component stereo systems, separate mini-component stereo systems, tuners, cassette decks, CD players, audio amplifiers, and car audio systems	

8/16-Bit Single Chip Microcontroller

78K/0 Series

■ 78K/0 Series Products (12/32) ◀ ▶

Subseries name			μ PD780232 Subseries	
Part number			μ PD780232*	μ PD78F0233*
Number of basic instructions			63	
Minimum instruction execution time			0.4 μ s (5.0 MHz)	
Instruction cycle			Selectable from 0.4 μ s, 0.8 μ s, 1.6 μ s, 3.2 μ s and 6.4 μ s (5.0 MHz)	
Internal memory	ROM	Size (bytes)	16K	24K (Flash memory)
	RAM	Size (bytes)	768	
Interrupt function		External	2	
		Internal	12	
I/O pin	CMOS I/O		11	
	P-ch open-drain I/O		29	
	P-ch open-drain output		24	
Timer			8-bit remote control timer \times 1 channel 8-bit timer \times 2 channels Watchdog timer \times 1 channel	
Timer output			3 (PWM output: 2)	
Serial interface			2-wire: 1 channel 3-wire (with function for automatic transmission and reception of up to 32 bytes): 1 channel	
A/D converter			8-bit resolution \times 4 channels	
FIP controller/driver			Display outputs: 53	
Standby function			STOP/HALT	
Operating power supply voltage range			$V_{DD} = 4.5$ to 5.5 V	
Package			80-pin plastic QFP (14 \times 14 mm, 0.65-mm pitch)	
Assembler			RA78K0	
C compiler			CC78K0	
Real-time OS			RX78K0, MX78K0	
Integrated debugger			ID78K0 or ID78K0-NS	
			DF780234*	
In-circuit emulator			IE-78001-R-A (with ID78K0), IE-78K0-NS (with ID78K0-NS)	
			IE-78K0-NS-P01 + IE-780233-NS-EM4*	
			With IE-78001-R-A: EP-78230GC-R + IE-78K0-R-EX1 With IE-78K0-NS: NP-80GC *	
Applications			Combined mini-component stereo systems, separate mini-component stereo systems, tuners, cassette tape decks, compact disc/mini disc players, audio amplifiers, etc.	

*: This is a product of Naito Densai Machidaseisakusho Co., Ltd.

*: Under development

8/16-Bit Single Chip Microcontroller

78K/0 Series

■ 78K/0 Series Products (13/32) ◀▶

Subseries name		μPD78054 Subseries								
Part number		μPD78052	μPD78053	μPD78054	μPD78P054	μPD78055	μPD78056	μPD78058	μPD78P058	
Number of basic instructions		63								
Minimum instruction execution time		0.4 μs (5.0 MHz)								
Instruction cycle	When main system clock is selected	Selectable from 0.4 μs, 0.8 μs, 1.6 μs, 3.2 μs, 6.4 μs, and 12.8 μs (5.0 MHz)								
	When subsystem clock is selected	122 μs (32.768 kHz)								
Internal memory	ROM	Size (bytes)	16K	24K	32K	32K (PROM)	40K	48K	60K	60K (PROM)
	RAM	Size (bytes)	544	1056				2080		
Address space		64K bytes								
Interrupt function	External	7								
	Internal	15								
I/O pin	CMOS input	2								
	CMOS I/O	63								
	N-ch open-drain I/O	4								
Timer	16-bit timer/event counter × 1 channel 8-bit timer/event counter × 2 channels Clock timer × 1 channel Watchdog timer × 1 channel									
Timer output	3 (PWM output: 1)									
Serial interface	3-wire/SBI/2-wire mode (selectable): 1 channel 3-wire (with function for automatic transmission and reception of up to 32 bytes): 1 channel 3-wire/UART mode (selectable): 1 channel									
A/D converter	8-bit resolution × 8 channels									
D/A converter	8-bit resolution × 2 channels									
Others	Clock output function Buzzer output function									
Standby function	STOP/HALT									
Operating power supply voltage range	2.0 to 6.0 V									
Package	<ul style="list-style-type: none"> • 80-pin plastic QFP (14 × 14 mm, 0.65-mm pitch) • 80-pin plastic QFP (12 × 12 mm, 0.5-mm pitch) 			*1	<ul style="list-style-type: none"> • 80-pin plastic QFP (14 × 14 mm) 			*2	*3	
Assembler	RA78K0									
C compiler	CC78K0									
Real-time OS	MX78K0	RX78K0, MX78K0								
Integrated debugger	ID78K0 or ID78K0-NS									
	DF78054									
In-circuit emulator	IE-78001-R-A (with ID78K0), IE-78K0-NS (with ID78K0-NS)									
	With IE-78001-R-A: IE-780308-R-EM, with IE-78K0-NS: IE-780308-NS-EM1									
	With IE-78001-R-A: EP-78230GC-R, EP-78054GK-R With IE-78K0-NS: NP-80GC *4, NP-80GK *4									
Applications	Cellular phones, pagers, printers, AV equipments, air conditioners, cameras, PPCs, fuzzy home appliances, vending machines, etc.									

- *1: • 80-pin plastic QFP (14 × 14 mm, 0.65-mm pitch)
• 80-pin plastic QFP (12 × 12 mm, 0.5-mm pitch)
• 80-pin ceramic WQFN (14 × 14 mm)
- *2: • 80-pin plastic QFP (14 × 14 mm)
• 80-pin plastic QFP (12 × 12 mm)
- *3: • 80-pin plastic QFP (14 × 14 mm)
• 80-pin ceramic WQFN (14 × 14 mm)

*4: This is a product of Naito Densai Machidaseisakusho Co., Ltd.

8/16-Bit Single Chip Microcontroller

78K/0 Series

■ 78K/0 Series Products (14/32) ◀ ▶

Subseries name		μPD78054Y Subseries							
Part number		μPD78052Y	μPD78053Y	μPD78054Y	μPD78055Y	μPD78056Y	μPD78058Y	μPD78P058Y	
Number of basic instructions		63							
Minimum instruction execution time		0.4 μs (5.0 MHz)							
Instruction cycle	When main system clock is selected	Selectable from 0.4 μs, 0.8 μs, 1.6 μs, 3.2 μs, 6.4 μs, and 12.8 μs (5.0 MHz)							
	When subsystem clock is selected	122 μs (32.768 kHz)							
Internal memory	ROM	Size (bytes)	16K	24K	32K	40K	48K	60K	60K (PROM)
	RAM	Size (bytes)	544	1056				2080	
Address space		64K bytes							
Interrupt function	External	7							
	Internal	15							
I/O pin	CMOS input		2						
	CMOS I/O		63						
	N-ch open-drain I/O		4						
Timer		16-bit timer/event counter × 1 channel 8-bit timer/event counter × 2 channels Clock timer × 1 channel Watchdog timer × 1 channel							
Timer output		3 (PWM output: 1)							
Serial interface		3-wire/I ² C bus/2-wire mode (selectable): 1 channel 3-wire (with function for automatic transmission and reception of up to 32 bytes): 1 channel 3-wire/UART mode (selectable): 1 channel							
A/D converter		8-bit resolution × 8 channels							
D/A converter		8-bit resolution × 2 channels							
Others		Clock output function Buzzer output function							
Standby function		STOP/HALT							
Operating power supply voltage range		2.0 to 6.0 V							
Package		• 80-pin plastic QFP (14 × 14 mm, 0.65-mm pitch)			• 80-pin plastic QFP (14 × 14 mm)			*1	*2
Assembler		RA78K0							
C compiler		CC78K0							
Real-time OS		MX78K0	RX78K0, MX78K0						
Integrated debugger		ID78K0 or ID78K0-NS							
		DF78054							
In-circuit emulator		IE-78001-R-A (with ID78K0), IE-78K0-NS (with ID78K0-NS)							
		With IE-78001-R-A: IE-780308-R-EM, with IE-78K0-NS: IE-780308-NS-EM1							
		With IE-78001-R-A: EP-78230GC-R, EP-78054GK-R With IE-78K0-NS: NP-80GC *3, NP-80GK *3							
Applications		Cellular phones, pagers, printers, AV equipments, air conditioners, cameras, PPCs, fuzzy home appliances, vending machines, etc.							

*1: • 80-pin plastic QFP (14 × 14 mm)

• 80-pin plastic QFP (12 × 12 mm)

*2: • 80-pin plastic QFP (14 × 14 mm)

• 80-pin ceramic WQFN (14 × 14 mm)

*3: This is a product of Naito Densai Machidaseisakusho Co., Ltd.

8/16-Bit Single Chip Microcontroller

78K/0 Series

■ 78K/0 Series Products (15/32) ◀ ▶

Subseries name			μ PD78058F Subseries		
Part number			μ PD78056F	μ PD78058F	μ PD78P058F
Number of basic instructions			63		
Minimum instruction execution time			0.4 μ s (5.0 MHz)		
Instruction cycle	When main system clock is selected		Selectable from 0.4 μ s, 0.8 μ s, 1.6 μ s, 3.2 μ s, 6.4 μ s, and 12.8 μ s (5.0 MHz)		
	When subsystem clock is selected		122 μ s (32.768 kHz)		
Internal memory	ROM	Size (bytes)	48K	60K	60K (PROM)
	RAM	Size (bytes)	1056	2080	
Address space			64K bytes		
Interrupt function	External		7		
	Internal		15		
I/O pin	CMOS input		2		
	CMOS I/O		63		
	N-ch open-drain I/O		4		
Timer			16-bit timer/event counter \times 1 channel 8-bit timer/event counter \times 2 channels Clock timer \times 1 channel Watchdog timer \times 1 channel		
Timer output			3 (PWM output: 1)		
Serial interface			3-wire/SBI/2-wire mode (selectable): 1 channel 3-wire (with function for automatic transmission and reception of up to 32 bytes): 1 channel 3-wire/UART mode (selectable): 1 channel		
A/D converter			8-bit resolution \times 8 channels		
D/A converter			8-bit resolution \times 2 channels		
Others			Clock output function Buzzer output function		
Standby function			STOP/HALT		
Operating power supply voltage range			2.7 to 6.0 V		
Package			<ul style="list-style-type: none"> • 80-pin plastic QFP (14 \times 14 mm, 0.65-mm pitch) 	<ul style="list-style-type: none"> • 80-pin plastic QFP (14 \times 14 mm, 0.65-mm pitch) • 80-pin plastic QFP (12 \times 12 mm, 0.5-mm pitch) 	<ul style="list-style-type: none"> • 80-pin plastic QFP (14 \times 14 mm)
Assembler			RA78K0		
C compiler			CC78K0		
Real-time OS			RX78K0, MX78K0		
Integrated debugger			ID78K0 or ID78K0-NS DF78054		
In-circuit emulator			IE-78001-R-A (with ID78K0), IE-78K0-NS (with ID78K0-NS) With IE-78001-R-A: IE-780308-R-EM, with IE-78K0-NS: IE-780308-NS-EM1 With IE-78001-R-A: EP-78230GC-R, EP-78054GK-R With IE-78K0-NS: NP-80GC *, NP-80GK *		
Applications			Cellular phones, AV equipments, car stereo, cameras, PPCs, etc.		

*: This is a product of Naito Densai Machidaseisakusho Co., Ltd.

8/16-Bit Single Chip Microcontroller

78K/0 Series

■ 78K/0 Series Products (16/32) ◀ ▶

Subseries name		μPD78058FY Subseries		
Part number		μPD78056FY	μPD78058FY	μPD78P058FY
Number of basic instructions		63		
Minimum instruction execution time		0.4 μs (5.0 MHz)		
Instruction cycle	When main system clock is selected	Selectable from 0.4 μs, 0.8 μs, 1.6 μs, 3.2 μs, 6.4 μs, and 12.8 μs (5.0 MHz)		
	When subsystem clock is selected	122 μs (32.768 kHz)		
Internal memory	ROM	Size (bytes)	48K	60K
	RAM	Size (bytes)	1056	2080
Address space		64K bytes		
Interrupt function	External	7		
	Internal	15		
I/O pin	CMOS input		2	
	CMOS I/O		63	
	N-ch open-drain I/O		4	
Timer		16-bit timer/event counter × 1 channel 8-bit timer/event counter × 2 channels Clock timer × 1 channel Watchdog timer × 1 channel		
Timer output		3 (PWM output: 1)		
Serial interface		3-wire/I ² C bus/2-wire mode (selectable): 1 channel 3-wire (with function for automatic transmission and reception of up to 32 bytes): 1 channel 3-wire/UART mode (selectable): 1 channel		
A/D converter		8-bit resolution × 8 channels		
D/A converter		8-bit resolution × 2 channels		
Others		Clock output function Buzzer output function		
Standby function		STOP/HALT		
Operating power supply voltage range		2.7 to 6.0 V		
Package		<ul style="list-style-type: none"> 80-pin plastic QFP (14 × 14 mm, 0.65-mm pitch) 	<ul style="list-style-type: none"> 80-pin plastic QFP (14 × 14 mm, 0.65-mm pitch) 80-pin plastic QFP (12 × 12 mm, 0.5-mm pitch) 	<ul style="list-style-type: none"> 80-pin plastic QFP (14 × 14 mm)
Assembler		RA78K0		
C compiler		CC78K0		
Real-time OS		RX78K0, MX78K0		
Integrated debugger		ID78K0 or ID78K0-NS DF78054		
In-circuit emulator		IE-78001-R-A (with ID78K0), IE-78K0-NS (with ID78K0-NS) With IE-78001-R-A: IE-780308-R-EM, with IE-78K0-NS: IE-780308-NS-EM1 With IE-78001-R-A: EP-78230GC-R, EP-78054GK-R With IE-78K0-NS: NP-80GC *, NP-80GK *		
Applications		Cellular phones, AV equipments, car stereo, cameras, PPCs, etc.		

*: This is a product of Naito Densai Machidaseisakusho Co., Ltd.

8/16-Bit Single Chip Microcontroller

78K/0 Series

■ 78K/0 Series Products (17/32) ◀▶

Subseries name		μPD780058 Subseries						
Part number		μPD780053*	μPD780054*	μPD780055*	μPD780056*	μPD780058*	μPD78F0058*	
Number of basic instructions		63						
Minimum instruction execution time		0.4 μs (5.0 MHz)						
Instruction cycle	When main system clock is selected	Selectable from 0.4 μs, 0.8 μs, 1.6 μs, 3.2 μs, 6.4 μs, and 12.8 μs (5.0 MHz)						
	When subsystem clock is selected	122 μs (32.768 kHz)						
Internal memory	ROM	Size (bytes)	24K	32K	40K	48K	60K	60K (Flash memory)
	RAM	Size (bytes)	1056				2080	
Address space		64K bytes						
Interrupt function	External	7						
	Internal	15						
I/O pin	CMOS input	2						
	CMOS I/O	62						
	N-ch open-drain I/O	4						
Timer		16-bit timer/event counter × 1 channel 8-bit timer/event counter × 2 channels Clock timer × 1 channel Watchdog timer × 1 channel						
Timer output		3 (PWM output: 1)						
Serial interface		3-wire/SBI/2-wire mode (selectable): 1 channel 3-wire (with function for automatic transmission and reception of up to 32 bytes): 1 channel 3-wire/UART mode (with time-division transmission function) (selectable): 1 channel						
A/D converter		8-bit resolution × 8 channels						
D/A converter		8-bit resolution × 2 channels						
Others		Clock output function Buzzer output function						
Standby function		STOP/HALT						
Operating power supply voltage range		1.8 to 5.5 V						
Package		<ul style="list-style-type: none"> • 80-pin plastic QFP (14 × 14 mm, 0.65-mm pitch) • 80-pin plastic TQFP (12 × 12 mm, 0.5-mm pitch) 						
Assembler		RA78K0						
C compiler		CC78K0						
Real-time OS		RX78K0, MX78K0						
Integrated debugger		ID78K0 or ID78K0-NS DF780058*						
In-circuit emulator		IE-78001-R-A (with ID78K0), IE-78K0-NS (with ID78K0-NS) With IE-78001-R-A: IE-780308-R-EM, with IE-78K0-NS: IE-780308-NS-EM1 With IE-78001-R-A: EP-78230GC-R With IE-78K0-NS: NP-80GC *, NP-80GK *						
Applications		Cellular phones, pagers, printers, AV equipments, air conditioners, cameras, PPCs, fuzzy home appliances, vending machines, etc.						

*: This is a product of Naito Densai Machidaseisakusho Co., Ltd.

*: Under development

8/16-Bit Single Chip Microcontroller

78K/0 Series

■ 78K/0 Series Products (18/32) ◀▶

Subseries name		μPD780058Y Subseries					
Part number		μPD780053Y*	μPD780054Y*	μPD780055Y*	μPD780056Y*	μPD780058Y*	μPD78F0058Y*
Number of basic instructions		63					
Minimum instruction execution time		0.4 μs (5.0 MHz)					
Instruction cycle	When main system clock is selected	Selectable from 0.4 μs, 0.8 μs, 1.6 μs, 3.2 μs, 6.4 μs, and 12.8 μs (5.0 MHz)					
	When subsystem clock is selected	122 μs (32.768 kHz)					
Internal memory	ROM	Size (bytes)	24K	32K	40K	48K	60K (Flash memory)
	RAM	Size (bytes)	1056			2080	
Address space		64K bytes					
Interrupt function	External	7					
	Internal	15					
I/O pin	CMOS input	2					
	CMOS I/O	62					
	N-ch open-drain I/O	4					
Timer		16-bit timer/event counter × 1 channel 8-bit timer/event counter × 2 channels Clock timer × 1 channel Watchdog timer × 1 channel					
Timer output		3 (PWM output: 1)					
Serial interface		3-wire/I ² C bus/2-wire mode (selectable): 1 channel 3-wire (with function for automatic transmission and reception of up to 32 bytes): 1 channel 3-wire/UART mode (with time-division transmission function) (selectable): 1 channel					
A/D converter		8-bit resolution × 8 channels					
D/A converter		8-bit resolution × 2 channels					
Others		Clock output function Buzzer output function					
Standby function		STOP/HALT					
Operating power supply voltage range		1.8 to 5.5 V					
Package		<ul style="list-style-type: none"> • 80-pin plastic QFP (14 × 14 mm, 0.65-mm pitch) • 80-pin plastic TQFP (12 × 12 mm, 0.5-mm pitch) 					
Assembler		RA78K0					
C compiler		CC78K0					
Real-time OS		RX78K0, MX78K0					
Integrated debugger		ID78K0 or ID78K0-NS					
		DF780058*					
In-circuit emulator		IE-78001-R-A (with ID78K0), IE-78K0-NS (with ID78K0-NS)					
		With IE-78001-R-A: IE-780308-R-EM, with IE-78K0-NS: IE-780308-NS-EM1					
		With IE-78001-R-A: EP-78230GC-R, EP-78054GK-R With IE-78K0-NS: NP-80GC *, NP-80GK *					
Applications		Cellular phones, pagers, printers, AV equipments, air conditioners, cameras, PPCs, fuzzy home appliances, vending machines, etc.					

*: This is a product of Naito Densai Machidaseisakusho Co., Ltd.

*: Under development

8/16-Bit Single Chip Microcontroller

78K/0 Series

■ 78K/0 Series Products (19/32) ◀▶

Subseries name		μPD78064 Subseries				μPD78064B Subseries		
Part number		μPD78062	μPD78063	μPD78064	μPD78P064	μPD78064B	μPD78P064B	
Number of basic instructions		63						
Minimum instruction execution time		0.4 μs (5.0 MHz)						
Instruction cycle	When main system clock is selected	Selectable from 0.4 μs, 0.8 μs, 1.6 μs, 3.2 μs, 6.4 μs, and 12.8 μs (5.0 MHz)						
	When subsystem clock is selected	122 μs (32.768 kHz)						
Internal memory	ROM	Size (bytes)	16K	24K	32K	32K (PROM)	32K	32K (PROM)
	RAM	Size (bytes)	532	1044				
Interrupt function	External		6					
	Internal		14					
I/O pin	CMOS input		2					
	CMOS I/O		55					
Timer		16-bit timer/event counter × 1 channel 8-bit timer/event counter × 2 channels Clock timer × 1 channel Watchdog timer × 1 channel						
Timer output		3 (PWM output: 1)						
Serial interface		3-wire/SBI/2-wire mode (selectable): 1 channel 3-wire/UART mode (selectable): 1 channel						
A/D converter		8-bit resolution × 8 channels						
LCD controller/driver		Number of segment signal outputs: 40 maximum Number of common signal outputs: 4 maximum Bias: 1/2 or 1/3 (switchable)						
Others		Clock output function Buzzer output function						
Standby function		STOP/HALT						
Operating power supply voltage range		2.0 to 6.0 V						
Package		<ul style="list-style-type: none"> • 100-pin plastic QFP (14 × 20 mm, 0.65-mm pitch) • 100-pin plastic QFP (14 × 14 mm, 0.5-mm pitch) 						
Assembler		RA78K0						
C compiler		CC78K0						
Real-time OS		MX78K0	RX78K0, MX78K0					
Integrated debugger		ID78K0 or ID78K0-NS DF78064						
In-circuit emulator		IE-78001-R-A (with ID78K0), IE-78K0-NS (with ID78K0-NS) With IE-78001-R-A: IE-780308-R-EM, with IE-78K0-NS: IE-780308-NS-EM1 With IE-78001-R-A: EP-78064GF-R, EP-78064GC-R With IE-78K0-NS: NP-100GF *, NP-100GC *						
Applications		Cellular phones, CD players, cameras, etc.						

*: This is a product of Naito Densai Machidaseisakusho Co., Ltd.

8/16-Bit Single Chip Microcontroller

78K/0 Series

■ 78K/0 Series Products (20/32) ◀ ▶

Subseries name		μ PD78064Y Subseries		
Part number		μ PD78062Y	μ PD78063Y	μ PD78064Y
Number of basic instructions		63		
Minimum instruction execution time		0.4 μ s (5.0 MHz)		
Instruction cycle	When main system clock is selected	Selectable from 0.4 μ s, 0.8 μ s, 1.6 μ s, 3.2 μ s, 6.4 μ s, and 12.8 μ s (5.0 MHz)		
	When subsystem clock is selected	122 μ s (32.768 kHz)		
Internal memory	ROM	Size (bytes)	16K	24K
	RAM	Size (bytes)	532	1044
Interrupt function	External		6	
	Internal		14	
I/O pin	CMOS input		2	
	CMOS I/O		55	
Timer		16-bit timer/event counter \times 1 channel 8-bit timer/event counter \times 2 channels Clock timer \times 1 channel Watchdog timer \times 1 channel		
Timer output		3 (PWM output: 1)		
Serial interface		3-wire/2-wire/I ² C bus mode (selectable): 1 channel 3-wire/UART mode (selectable): 1 channel		
A/D converter		8-bit resolution \times 8 channels		
LCD controller/driver		Number of segment signal outputs: 40 maximum Number of common signal outputs: 4 maximum Bias: 1/2 or 1/3 (switchable)		
Others		Clock output function Buzzer output function		
Standby function		STOP/HALT		
Operating power supply voltage range		2.0 to 6.0 V		
Package		<ul style="list-style-type: none"> • 100-pin plastic QFP (14 \times 20 mm, 0.65-mm pitch) • 100-pin plastic QFP (14 \times 14 mm, 0.5-mm pitch) 		
Assembler		RA78K0		
C compiler		CC78K0		
Real-time OS		MX78K0	RX78K0, MX78K0	
Integrated debugger		ID78K0 or ID78K0-NS		
		DF78064		
In-circuit emulator		IE-78001-R-A (with ID78K0), IE-78K0-NS (with ID78K0-NS)		
		With IE-78001-R-A: IE-780308-R-EM, with IE-78K0-NS: IE-780308-NS-EM1		
		With IE-78001-R-A: EP-78064GF-R, EP-78064GC-R With IE-78K0-NS: NP-100GF *, NP-100GC *		
Applications		Cellular phones, CD players, cameras, etc.		

*: This is a product of Naito Densai Machidaseisakusho Co., Ltd.

8/16-Bit Single Chip Microcontroller

78K/0 Series

■ 78K/0 Series Products (21/32) ◀▶

Subseries name			μPD780308 Subseries			μPD780308Y Subseries		
Part number			μPD780306	μPD780308	μPD78P0308*	μPD780306Y	μPD780308Y	μPD78P0308Y*
Number of basic instructions			63					
Minimum instruction execution time			0.4 μs (5.0 MHz)					
Instruction cycle	When main system clock is selected		Selectable from 0.4 μs, 0.8 μs, 1.6 μs, 3.2 μs, 6.4 μs, and 12.8 μs (5.0 MHz)					
	When subsystem clock is selected		122 μs (32.768 kHz)					
Internal memory	ROM	Size (bytes)	48K	60K		48K	60K	60K (PROM)
	RAM	Size (bytes)	2068					
Address space			64K bytes					
Interrupt function	External		6					
	Internal		15					
I/O pin	CMOS input		2					
	CMOS I/O		55					
Timer			16-bit timer/event counter × 1 channel 8-bit timer/event counter × 2 channels Clock timer × 1 channel Watchdog timer × 1 channel					
Timer output			3 (PWM output: 1)					
Serial interface			3-wire/SBI/2-wire mode (selectable): 1 channel 3-wire/UART mode (selectable): 1 channel 3-wire (with time-division transmission function): 1 channel			3-wire/I ² C bus/2-wire mode (selectable): 1 channel 3-wire/UART mode (selectable): 1 channel 3-wire (with time-division transmission function): 1 channel		
A/D converter			8-bit resolution × 8 channels					
LCD controller/driver			Number of segment signal outputs: 40 maximum Number of common signal outputs: 4 maximum Bias: 1/2 or 1/3 (switchable)					
Others			Clock output function Buzzer output function					
Standby function			STOP/HALT					
Operating power supply voltage range			2.0 to 5.5 V					
Package			<ul style="list-style-type: none"> • 100-pin plastic QFP (14 × 20 mm, 0.65-mm pitch) • 100-pin plastic LQFP (14 × 14 mm, 0.5-mm pitch) 		*1	<ul style="list-style-type: none"> • 100-pin plastic QFP (14 × 20 mm, 0.65-mm pitch) • 100-pin plastic LQFP (14 × 14 mm, 0.5-mm pitch) 		*1
Assembler			RA78K0					
C compiler			CC78K0					
Real-time OS			RX78K0, MX78K0					
Integrated debugger			ID78K0 or ID78K0-NS DF780308 (Part number: μSxxxxDF78064)					
In-circuit emulator			IE-78001-R-A (with ID78K0), IE-78K0-NS (with ID78K0-NS)					
			With IE-78001-R-A: IE-780308-R-EM, with IE-78K0-NS: IE-780308-NS-EM1					
			With IE-78001-R-A: EP-78064GF-R, EP-78064GC-R With IE-78K0-NS: NP-100GF *2, NP-100GC *2					
Applications			Cellular phones, pagers, CD players, meters, etc.					

- *1: • 100-pin plastic QFP (14 × 20 mm, 0.65-mm pitch)
• 100-pin plastic QFP (14 × 14 mm, 0.5-mm pitch)
• 100-pin ceramic WQFN (14 × 20 mm)

*2: Under development

*2: This is a product of Naito Densai Machidaseisakusho Co., Ltd.

8/16-Bit Single Chip Microcontroller

78K/0 Series

■ 78K/0 Series Products (22/32) ◀▶

Subseries name		μPD78075B Subseries		μPD78078 Subseries		
Part number		μPD78074B	μPD78075B	μPD78076	μPD78078	μPD78P078
Number of basic instructions		63				
Minimum instruction execution time		0.4 μs (5.0 MHz)				
Instruction cycle	When main system clock is selected	Selectable from 0.4 μs, 0.8 μs, 1.6 μs, 3.2 μs, 6.4 μs, and 12.8 μs (5.0 MHz)				
	When subsystem clock is selected	122 μs (32.768 kHz)				
Internal memory	ROM	Size (bytes)	32K	40K	48K	60K
	RAM	Size (bytes)	1056		2080	
Address space		64K bytes				
Interrupt function	External	7				
	Internal	17				
I/O pin	CMOS input		2			
	CMOS I/O		78			
	N-ch open-drain I/O		8			
Timer		16-bit timer/event counter × 1 channel 8-bit timer/event counter × 4 channels Clock timer × 1 channel Watchdog timer × 1 channel				
Timer output		3 (PWM output: 1)				
Serial interface		3-wire/SBI/2-wire mode (selectable): 1 channel 3-wire (with function for automatic transmission and reception of up to 32 bytes): 1 channel 3-wire/UART mode (selectable): 1 channel				
A/D converter		8-bit resolution × 8 channels				
D/A converter		8-bit resolution × 2 channels				
Others		Clock output function Buzzer output function				
Standby function		STOP/HALT				
Operating power supply voltage range		1.8 to 5.5 V				
Package		<ul style="list-style-type: none"> • 100-pin plastic QFP (14 × 20 mm, 0.65-mm pitch) • 100-pin plastic QFP (14 × 14 mm, 0.5-mm pitch) 				*1
Assembler		RA78K0				
C compiler		CC78K0				
Real-time OS		RX78K0, MX78K0				
Integrated debugger		ID78K0 or ID78K0-NS DF78078				
In-circuit emulator		IE-78001-R-A (with ID78K0), IE-78K0-NS (with ID78K0-NS)				
		With IE-78001-R-A: IE-78078-R-EM, with IE-78K0-NS: IE-78078-NS-EM1				
		With IE-78001-R-A: EP-78064GF-R, EP-78064GC-R With IE-78K0-NS: NP-100GF *2, NP-100GC *2				
Applications		Cellular phones, cordless phones, audio equipments, VCRs, printers, etc.				

*1: • 100-pin plastic QFP (14 × 20 mm, 0.65-mm pitch)

• 100-pin plastic QFP (14 × 14 mm, 0.5-mm pitch)

• 100-pin ceramic WQFN (14 × 20 mm)

*2: This is a product of Naito Densai Machidaseisakusho Co., Ltd.

8/16-Bit Single Chip Microcontroller

78K/0 Series

■ 78K/0 Series Products (23/32) ◀▶

Subseries name			μ PD78078Y Subseries		
Part number			μ PD78076Y	μ PD78078Y	μ PD78P078Y
Number of basic instructions			63		
Minimum instruction execution time			0.4 μ s (5.0 MHz)		
Instruction cycle	When main system clock is selected		Selectable from 0.4 μ s, 0.8 μ s, 1.6 μ s, 3.2 μ s, 6.4 μ s, and 12.8 μ s (5.0 MHz)		
	When subsystem clock is selected		122 μ s (32.768 kHz)		
Internal memory	ROM	Size (bytes)	48K	60K	60K (PROM)
	RAM	Size (bytes)	2080		
Address space			64K bytes		
Interrupt function	External		7		
	Internal		17		
I/O pin	CMOS input		2		
	CMOS I/O		78		
	N-ch open-drain I/O		8		
Timer			16-bit timer/event counter \times 1 channel 8-bit timer/event counter \times 4 channels Clock timer \times 1 channel Watchdog timer \times 1 channel		
Timer output			3 (PWM output: 1)		
Serial interface			3-wire/2-wire/I ² C bus mode (selectable): 1 channel 3-wire (with function for automatic transmission and reception of up to 32 bytes): 1 channel 3-wire/UART mode (selectable): 1 channel		
A/D converter			8-bit resolution \times 8 channels		
D/A converter			8-bit resolution \times 2 channels		
Others			Clock output function Buzzer output function		
Standby function			STOP/HALT		
Operating power supply voltage range			1.8 to 5.5 V		
Package			<ul style="list-style-type: none"> • 100-pin plastic QFP (14 \times 20 mm, 0.65-mm pitch) • 100-pin plastic QFP (14 \times 14 mm, 0.5-mm pitch) 		*1
Assembler			RA78K0		
C compiler			CC78K0		
Real-time OS			RX78K0, MX78K0		
Integrated debugger			ID78K0 or ID78K0-NS		
			DF78078		
In-circuit emulator			IE-78001-R-A (with ID78K0), IE-78K0-NS (with ID78K0-NS)		
			With IE-78001-R-A: IE-78078-R-EM, with IE-78K0-NS: IE-78078-NS-EM1		
			With IE-78001-R-A: EP-78064GF-R, EP-78064GC-R With IE-78K0-NS: NP-100GF *2, NP-100GC *2		
Applications			VCRs, TVs, audio equipments, etc.		

- *1: • 100-pin plastic QFP (14 \times 20 mm, 0.65-mm pitch)
• 100-pin plastic QFP (14 \times 14 mm, 0.5-mm pitch)
• 100-pin ceramic WQFN (14 \times 20 mm)

*2: This is a product of Naito Densai Machidaseisakusho Co., Ltd.

8/16-Bit Single Chip Microcontroller

78K/0 Series

■ 78K/0 Series Products (24/32) ◀▶

Part number		μ PD78070A	μ PD78070AY
Number of basic instructions		63	
Minimum instruction execution time		0.4 μ s (5.0 MHz)	
Instruction cycle	When main system clock is selected	Selectable from 0.4 μ s, 0.8 μ s, 1.6 μ s, 3.2 μ s, 6.4 μ s, and 12.8 μ s (5.0 MHz)	
	When subsystem clock is selected	122 μ s (32.768 kHz)	
Internal memory	ROM	Size (bytes)	
	RAM	Size (bytes)	
Address space		64K bytes	
Interrupt function	External	7	
	Internal	17	
I/O pin	CMOS input	2	
	CMOS I/O	51	
	N-ch open-drain I/O	8	
Timer	16-bit timer/event counter \times 1 channel 8-bit timer/event counter \times 4 channels Clock timer \times 1 channel Watchdog timer \times 1 channel		
Timer output	3 (PWM output: 1)		
Serial interface	*1	*2	
A/D converter	8-bit resolution \times 8 channels		
D/A converter	8-bit resolution \times 2 channels		
Others	Clock output function Buzzer output function		
Standby function	STOP/HALT		
Operating power supply voltage range	2.7 to 5.5 V		
Package	<ul style="list-style-type: none"> • 100-pin plastic QFP (14 \times 20 mm, 0.65-mm pitch) • 100-pin plastic QFP (14 \times 14 mm, 0.5-mm pitch) 		
Assembler	RA78K0		
C compiler	CC78K0		
Real-time OS	RX78K0, MX78K0		
Integrated debugger	ID78K0 or ID78K0-NS		
	DF78078		
In-circuit emulator	IE-78001-R-A (with ID78K0), IE-78K0-NS (with ID78K0-NS)		
	With IE-78001-R-A: IE-78078-R-EM, with IE-78K0-NS: IE-78078-NS-EM1		
	With IE-78001-R-A: EP-78064GF-R, EP-78064GC-R With IE-78K0-NS: NP-100GF *3, NP-100GC *3		
Applications	CD-ROMs, printers, PPCs, etc.		

- *1: • 3-wire/SBI/2-wire mode (selectable): 1 channel
• 3-wire (with function for automatic transmission and reception of up to 32 bytes): 1 channel
• 3-wire/UART mode (selectable): 1 channel
- *2: • 3-wire/2-wire/I²C bus mode selectable: 1 channel
• 3-wire (with function for automatic transmission and reception of up to 32 bytes): 1 channel
• 3-wire/UART mode (selectable): 1 channel
- *3: This is a product of Naito Densai Machidaseisakusho Co., Ltd.

8/16-Bit Single Chip Microcontroller

78K/0 Series

■ 78K/0 Series Products (25/32) ◀▶

Subseries name		μ PD78083 Subseries			
Part number		μ PD78081	μ PD78082	μ PD78P083	
Number of basic instructions		63			
Minimum instruction execution time		0.4 μ s (5.0 MHz)			
Instruction cycle		When main system clock is selected Selectable from 0.4 μ s, 0.8 μ s, 1.6 μ s, 3.2 μ s, 6.4 μ s and 12.8 μ s (5.0 MHz)			
Internal memory	ROM	Size (bytes)	8K	16K	24K (PROM)
	RAM	Size (bytes)	256	384	512
Address space		64K bytes			
Interrupt function	External		3		
	Internal		10		
I/O pin	CMOS input		1		
	CMOS I/O		32		
Timer		8-bit timer/event counter \times 2 channels Watchdog timer \times 1 channel			
Timer output		2 (PWM output: 2)			
Serial interface		3-wire/UART mode (selectable): 1 channel			
A/D converter		8-bit resolution \times 8 channels			
Others		Clock output function Buzzer output function			
Standby function		STOP/HALT			
Operating power supply voltage range		1.8 to 5.5 V			
Package		<ul style="list-style-type: none"> • 42-pin plastic shrink DIP (600 mil) • 44-pin plastic QFP (10 \times 10 mm, 0.8-mm pitch) 		<ul style="list-style-type: none"> • 42-pin plastic shrink DIP (600 mil) • 44-pin plastic QFP (10 \times 10 mm, 0.8-mm pitch) • 42-pin ceramic shrink DIP with window (600 mil) 	
Assembler		RA78K0			
C compiler		CC78K0			
Real-time OS		MX78K0			
Integrated debugger		ID78K0 or ID78K0-NS			
		DF78083			
In-circuit emulator		IE-78001-R-A (with ID78K0), IE-78K0-NS (with ID78K0-NS)			
		With IE-78001-R-A: IE-78078-R-EM, with IE-78K0-NS: IE-78078-NS-EM1			
		With IE-78001-R-A: EP-78083CU-R, EP-78083GB-R With IE-78K0-NS: NP-42CU *, NP-44GB *			
Applications		Airbags, OA equipments, display equipments, air conditioners, keyless entry, etc.			

*: This is a product of Naito Densai Machidaseisakusho Co., Ltd.

8/16-Bit Single Chip Microcontroller

78K/0 Series

■ 78K/0 Series Products (26/32) ◀ ▶

Subseries name		μPD78098B Subseries				
Part number		μPD78095B	μPD78096B	μPD78098B	μPD78P098B	
Number of basic instructions		63				
Minimum instruction execution time		0.4 μs (5.0 MHz)				
Instruction cycle	When main system clock is selected	Selectable from 0.5 μs, 1.0 μs, 2.0 μs, 4.0 μs, 8.0 μs, and 16.0 μs (6.0 MHz)				
	When subsystem clock is selected	122 μs (32.768 kHz)				
Internal memory	ROM	Size (bytes)	40K	48K	60K	60K (PROM)
	RAM	Size (bytes)	1056		3104	
Address space		64K bytes				
Interrupt function	External	7				
	Internal	16				
I/O pin	CMOS input		2			
	CMOS I/O		63			
	N-ch open-drain I/O		4			
Timer		16-bit timer/event counter × 1 channel 8-bit timer/event counter × 2 channels Clock timer × 1 channel Watchdog timer × 1 channel				
Timer output		3 (PWM output: 1)				
Serial interface		3-wire/SBI/2-wire mode (selectable): 1 channel 3-wire (with function for automatic transmission and reception of up to 32 bytes): 1 channel 3-wire/UART mode (selectable): 1 channel				
A/D converter		8-bit resolution × 8 channels				
D/A converter		8-bit resolution × 2 channels				
IEBus controller		Effective transmission speed: 26 kbps maximum				
Others		Clock output function Buzzer output function				
Standby function		STOP/HALT				
Operating power supply voltage range		2.7 to 6.0 V				
Package		• 80-pin plastic QFP (14 × 14 mm, 0.65-mm pitch)			*	
Assembler		RA78K0				
C compiler		CC78K0				
Real-time OS		RX78K0, MX78K0				
Integrated debugger		ID78K0				
		DF78098				
In-circuit emulator		IE-78001-R-A				
		IE-780908-R-EM				
		EP-78230GC-R				
Applications		Car audios, CD changers, etc.				

※: • 80-pin plastic QFP (14 × 14 mm, 0.65-mm pitch)
• 80-pin ceramic WQFN (14 × 14 mm)

8/16-Bit Single Chip Microcontroller

78K/0 Series

■ 78K/0 Series Products (27/32) ◀▶

Subseries name			μPD780988 Subseries				
Part number			μPD780983*	μPD780984*	μPD780986*	μPD780988*	μPD78F0988*
Number of basic instructions			63				
Minimum instruction execution time			0.24 μs (8.38 MHz)				
Instruction cycle			Selectable from 0.24 μs, 0.48 μs, 0.95 μs, 1.9 μs and 3.8 μs (8.38 MHz)				
Internal memory	ROM	Size (bytes)	24K	32K	48K	60K	60K (Flash memory)
	RAM	Size (bytes)	1024			2048	
Address space			64K bytes				
Interrupt function		External	8				
		Internal	16				
I/O pin	CMOS input		8				
	CMOS I/O		39				
Timer			10-bit timer for inverter control × 1 channel 16-bit timer/event counter × 2 channels 8-bit timer/event counter × 3 channels Watchdog timer × 1 channel				
Timer output			11 (PWM output: 5, inverter control output: 6)				
Serial interface			3-wire: 1 channel UART: 2 channels				
A/D converter			10-bit resolution × 8 channels				
Others			Real-time output port				
Standby function			STOP/HALT				
Operating power supply voltage range			V _{DD} = 4.0 to 5.5 V				
Package			64-pin plastic shrink DIP (750 mil) 64-pin plastic QFP (14 × 14 mm, 0.8 mm pitch)				
Assembler			RA78K0				
C compiler			CC78K0				
Real-time OS			RX78K0, MX78K0				
Integrated debugger			ID78K0 or ID78K0-NS				
			DF780988				
In-circuit emulator			IE-78001-R-A (with ID78K0), IE-78K0-NS (with ID78K0-NS)				
			IE-78K0-NS-P01 + IE-780988-NS-EM4				
			With IE-78001-R-A: EP-78240CW-R + IE-78K0-R-EX1, EP-78240GC-R + IE-78K0-R-EX1 With IE-78K0-NS: NP-64CW *, NP-64GC *				
Applications			Motor control for inverter-type air conditioners, washing machines, etc.				

*: This is a product of Naito Densai Machidaseisakusho Co., Ltd.

*: Under development

8/16-Bit Single Chip Microcontroller

78K/0 Series

■ 78K/0 Series Products (28/32) ◀ ▶

Part number		μPD780955*	
Number of basic instructions		62	
Minimum instruction execution time		52 μs (38.4 kHz)	
Internal memory	ROM	Size (bytes)	40K
	RAM	Size (bytes)	1024
Address space		64K bytes	
Interrupt function	External		7
	Internal		10
I/O pin	CMOS I/O		47
	N-ch open drain output		3
Timer		16-bit counter × 1 channel 8-bit timer/event counter × 1 channel 8-bit timer × 5 channels Watchdog timer × 1 channel	
Timer output		1	
Serial interface		UART: 2 channels	
A/D converter		8-bit resolution × 1 channel	
Others		Quality grade: Special (μPD780955(A)) only (for high reliability electronic equipment)	
Standby function		HALT	
Operating power supply voltage range		V _{DD} = 2.2 to 3.5 V	
Package		80-pin plastic QFP (14 × 20 mm, 0.8 mm pitch)	
Assembler		RA78K0	
C compiler		CC78K0	
Real-time OS		RX78K0, MX78K0	
Integrated debugger		ID78K0	
		DF780955	
In-circuit emulator		IE-78001-R-A or IE-78K0-NS	
		IE-78K0-SL-P01 + IE-780955-SL-EM4	
		EP-80GF-SL	
Applications		Gas meters, etc.	

*: Under development

8/16-Bit Single Chip Microcontroller

78K/0 Series

■ 78K/0 Series Products (29/32) ◀ ▶

Subseries name			μ PD780973 Subseries	
Part number			μ PD780973*	μ PD78F0974*
Number of basic instructions			63	
Minimum instruction execution time			0.24 μ s (8.38 MHz)	
Instruction cycle			Selectable from 0.24 μ s, 0.48 μ s, 0.95 μ s, 1.91 μ s, and 3.81 μ s (8.38 MHz)	
Internal memory	ROM	Size (bytes)	24K	32K (Flash memory)
	RAM	Size (bytes)	778	1034
	EEPROM	Size (bytes)	256	
Address space			64K bytes	
Interrupt function	External		3	
	Internal		17	
I/O pin	CMOS input		5	
	CMOS Output		18	
	CMOS I/O		35	
Timer			16-bit timer/event counter \times 1 channel 8-bit timer/event counter \times 3 channels Clock timer \times 1 channel Watchdog timer \times 1 channel	
Timer output			2 (PWM output: 2)	
Serial interface			3-wire: 1 channel UART: 1 channel	
A/D converter			8-bit resolution \times 5 channels	
LCD controller/driver			Number of segment signal outputs: 20 maximum Number of common signal outputs: 4 maximum Bias: 1/3	
Sound generator			Buzzer output signal with composed amplitude	
Meter controller/driver			4 meter control (Cross-coil or stepper motor)	
Others			Clock output function	
Standby function			STOP/HALT	
Operating power supply voltage range			4.5 to 5.5 V	
Package			• 80-pin plastic QFP (14 \times 20 mm, 0.8-mm pitch)	
Assembler			RA78K0	
C compiler			CC78K0	
Real-time OS			RX78K0, MX78K0	
Integrated debugger			ID78K0 or ID78K0-NS	
			DF780974	
In-circuit emulator			IE-78001-R-A (with ID78K0), IE-78K0-NS (with ID78K0-NS)	
			With IE-78001-R-A: IE-780974-SL-EM1 With IE-78K0-NS: IE-780974-NS-EM1	
			With IE-78001-R-A: EP-80GF-SL, with IE-78K0-NS: NP-80GF *	
Applications			Vehicle meters control (dashboard mounted)	

*: This is a product of Naito Densai Machidaseisakusho Co., Ltd.

*: Under development

8/16-Bit Single Chip Microcontroller

78K/0 Series

■ 78K/0 Series Products (30/32) ◀▶

Subseries name		μ PD780948 Subseries			
Part number		μ PD780948*	μ PD780949*	μ PD78F0948*	μ PD78F0949*
Number of basic instructions		63			
Minimum instruction execution time		0.25 μ s (8.0 MHz)			
Instruction cycle	When main system clock is selected	Selectable from 0.25 μ s, 0.5 μ s, 1 μ s, 2 μ s and 4 μ s (8.0 MHz)			
	When subsystem clock is selected	122 μ s (32.768 kHz)			
Internal memory	ROM	Size (bytes)	60K		60K (Flash memory)
	Internal fast RAM	Size (bytes)	1024		
	Internal expansion RAM	Size (bytes)	1024		
	EEPROM	Size (bytes)	–	256	–
Address space		64K bytes			
Interrupt function	External	5			
	Internal	24			
I/O pin	CMOS input	8			
	CMOS I/O	71			
Timer		16-bit timer/event counter \times 1 channel 16-bit timer \times 1 channel 8-bit timer/event counter \times 2 channels Watch timer \times 1 channel Watchdog timer \times 1 channel			
Timer output		4 (16-bit PWM output: 1, 8-bit PWM output: 2)			
Serial interface		3-wire: 1 channel 2-wire: 1 channel UART: 1 channel			
CAN controller		Conformed on CAN protocol Ver. 2.0 (part B), transmission speed: 500 kbps maximum			
A/D converter		8-bit resolution \times 8 channels			
LCD controller/driver		Segment signal output: 40 maximum Common signal output: 4 maximum Bias: 1/3 bias			
Power fail detect function		Battery voltage detect function			
Sound generator		Buzzer output function (with composed amplitude)			
Standby function		STOP/HALT			
Operating power supply voltage range		$V_{DD} = 4.0$ to 5.5 V			
Package		100-pin plastic QFP (14 \times 20 mm, 0.65 mm pitch)			
Assembler		RA78K0			
C compiler		CC78K0			
Real-time OS		RX78K0, MX78K0			
Integrated debugger	ID78K0				
	DF780948				
In-circuit emulator	IE-78001-R-A				
	IE-780948-SL-EM1 + IE780948-SL-EM4				
	EP-100GF-SL				
Applications		Control of automotive dashboard and electrical equipment in car body, etc.			

*: Under development

8/16-Bit Single Chip Microcontroller

78K/0 Series

■ 78K/0 Series Products (31/32) ◀ ▶

Subseries name			μPD780701Y Subseries		
Part number			μPD780701Y*	μPD780702Y*	μPD78F0701Y*
Number of basic instructions			63		
Minimum instruction execution time			0.32 μs (6.29 MHz)		
Instruction cycle			Selectable from 0.32 μs, 0.64 μs, 1.27 μs, 2.54 μs, and 5.09 μs (6.29 MHz)		
Internal memory	ROM	Size (bytes)	60K		60K (Flash memory)
	RAM	Size (bytes)	3552		
Address space			64K bytes		
Interrupt function		External	8		
		Internal	21		
I/O pin	CMOS I/O		56		
	TTL input/CMOS output		8		
	N-ch open-drain I/O		3		
Timer			16-bit timer/event counter × 2 channels 8-bit timer/event counter × 3 channels Watch timer × 1 channel Watchdog timer × 1 channel		
Timer output			5 (PWM output: 3)		
Serial interface			3-wire: 2 channels UART: 1 channel I ² C bus (supporting multi-master): 1 channel		
A/D converter			8-bit resolution × 16 channels		
Power fail detect function			battery voltage detect function		
Others			Clock output function Buzzer output function		
Bus controller		DCAN controller	IEBus controller	DCAN controller or IEBus controller	
Standby function			STOP/HALT		
Power supply voltage range			V _{DD} = 4.5 to 5.5 V		
Package			80-pin plastic QFP (14 × 14 mm)		
Assembler			RA78K0		
C compiler			CC78K0		
Real-time OS			RX78K0, MX78K0		
Integrated debugger			ID78K0 or ID78K0-NS		
			DF780701*		
In-circuit emulator			IE-78001-R-A (with ID78K0), IE-78K0-NS (with ID78K0-NS)		
			IE-780701-NS-EM1*		
			With IE-78001-R-A: EP-78230GC-R + IE-78K0-R-EX1 With IE-78K0-NS: NP-80GC *		
Applications			Car audio systems, etc.		

*: This is a product of Naito Densai Machidaseisakusho Co., Ltd.

*: Under development

8/16-Bit Single Chip Microcontroller

78K/0 Series

■ 78K/0 Series Products (32/32) ◀

Subseries name			μ PD780833Y Subseries		
Part number			μ PD780831Y*	μ PD780833Y*	μ PD78F0833Y*
Number of basic instructions			63		
Minimum instruction execution time			0.48 μ s (4.19 MHz)		
Instruction cycle			Selectable from 0.48 μ s, 0.96 μ s, 1.92 μ s, 3.84 μ s, and 7.68 μ s (4.19 MHz)		
Internal memory	ROM	Size (bytes)	60K		60K (Flash memory)
	RAM	Size (bytes)	3104		
Address space			64K bytes		
Interrupt function		External	9		
		Internal	20		
I/O pin	CMOS I/O		54		
	TTL input/CMOS output		8		
	N-ch open-drain I/O		3		
Timer			16-bit timer/event counter × 2 channels Watch timer × 1 channel Watchdog timer × 1 channel	16-bit timer/event counter × 2 channels 8-bit timer/event counter × 3 channels Watch timer × 1 channel Watchdog timer × 1 channel	
Timer output			5 (PWM output: 3)		
Serial interface			3-wire: 2 channels UART: 1 channel I ² C bus (supporting multi-master): 1 channel		
A/D converter			8-bit resolution × 8 channels × 2		
Others			Clock output function		
Bus controller			J1850 (CLASS2) bus interface		
Standby function			STOP/HALT		
Power supply voltage range			V _{DD} = 4.5 to 5.5 V		
Package			80-pin plastic QFP (14 × 14 mm)		
Assembler			RA78K0		
C compiler			CC78K0		
Real-time OS			RX78K0, MX78K0		
Integrated debugger			ID78K0 or ID78K0-NS		
			DF780831*		
In-circuit emulator			IE-78001-R-A (with ID78K0), IE-78K0-NS (with ID78K0-NS)		
			IE-780831-NS-EM4* + IE-78K0-NS-P02*		
			With IE-78001-R-A: EP-78230GC-R + IE-78K0-R-EX1 With IE-78K0-NS: NP-80GC *		
Applications			Car audio systems, etc.		

*: This is a product of Naito Densai Machidaseisakusho Co., Ltd.

*: Under development

8/16-Bit Single Chip Microcontroller

78K/II Series

■ 78K/II Series Products (1/2) ▶

Series name		μPD78214 Series				μPD78218A Series			μPD78244 Series	
Part number		μPD78212	μPD78213	μPD78214	μPD78P214	μPD78217A	μPD78218A	μPD78P218A	μPD78243	μPD78244
Number of instructions		65								
Minimum instruction cycle		333 ns/12 MHz	500 ns/12 MHz	333 ns/12 MHz		500 ns/12 MHz	333 ns/12 MHz		500 ns/12 MHz	333 ns/12 MHz
Memory space		Program memory: 64K bytes, Data memory: 1M bytes								
Internal memory	ROM	8K bytes	ROM-less	16K bytes	16K bytes (PROM)	ROM-less	32K bytes	32K bytes (PROM)	ROM-less EEPROM: 512 bytes	16K bytes EEPROM: 512 bytes
	RAM	384 bytes	512 bytes			1024 bytes			512 bytes	
Interrupt		2-level programmable priority, vectored/macro service								
	External source	7								
	Internal source	12							14	
	Number of interrupts supporting the use of a macro service	15								
	Type of macro service	3 types, 6 kinds				3 types, 11 kinds				
I/O pin	Input	14								
	Output	12								
	I/O	28	10	28		10	28		10	28
Timer/counter		16-bit timer/counter × 1 channel 8-bit timer/counter × 3 channels								
Serial interface		UART (with dedicated on-chip baud rate generator): 1 channel CSI (SBI capability): 1 channel								
A/D converter		8-bit resolution × 8 channels								
Comparator		None								
D/A converter		None								
PWM output		None								
Standby function		HALT/STOP mode								
Pseudo-SRAM refresh function		Provided								
Feature		<ul style="list-style-type: none"> General-purpose type with real-time output ports for easy stepper motor control 				<ul style="list-style-type: none"> Upwardly compatible with μPD78214 Series 			<ul style="list-style-type: none"> General-purpose type with real-time output ports for easy stepper motor control Internal EEPROM 	
Package		<ul style="list-style-type: none"> 64-pin plastic shrink DIP (750 mil) 68-pin plastic QFJ 64-pin plastic QFP (14 × 14 mm) 74-pin plastic QFP (20 × 20 mm) 64-pin plastic QUIP 64-pin ceramic shrink DIP with window (for μPD78P214 only) 				<ul style="list-style-type: none"> 64-pin plastic QFP (14 × 14 mm) 64-pin plastic shrink DIP (750 mil) 64-pin ceramic shrink DIP with window (for μPD78P218A only) 			<ul style="list-style-type: none"> 64-pin plastic QFP (14 × 14 mm) 64-pin plastic shrink DIP (750 mil) 	
Assembler		RA78K2								
C compiler		CC78K2								
Real-time OS		—				RX78K2			—	
Screen debugger		SD78K2								
		DF78210							DF78240	
In-circuit emulator		IE-78240-R-A								
Application		OA equipment such as printer, PPC, Fax, etc.								

8/16-Bit Single Chip Microcontroller

78K/II Series

■ 78K/II Series Products (2/2) ◀

Series name		μPD78234 Series				
Part number		μPD78233	μPD78234	μPD78237	μPD78238	μPD78P238
Number of instructions		65				
Minimum instruction cycle		500 ns/12 MHz	333 ns/12 MHz	500 ns/12 MHz	333 ns/12 MHz	
Memory space		Program memory: 64K bytes, Data memory: 1M bytes				
Internal memory	ROM	ROM-less	16K bytes	ROM-less	32K bytes	32K/16K bytes (PROM) *
	RAM	640 bytes		1024 bytes		1024/640 bytes *
Interrupt		2-level programmable priority, vectored/macro service				
External source		7				
Internal source		12				
Number of interrupts supporting the use of a macro service		15				
Type of macro service		3 types, 11 kinds				
I/O pin	Input	16				
	Output	12				
	I/O	18	36	18	36	
Timer/counter		16-bit timer/counter × 1 channel 8-bit timer/counter × 3 channels				
Serial interface		UART (with dedicated on-chip baud rate generator): 1 channel CSI (SBI capability): 1 channel				
A/D converter		8-bit resolution × 8 channels				
Comparator		None				
D/A converter		8-bit resolution × 2 channels				
PWM output		12-bit resolution × 2 channels				
Standby function		HALT/STOP mode				
Pseudo-SRAM refresh function		Provided				
Feature		<ul style="list-style-type: none"> Enhanced analog output function Large internal memory 				
Package		<ul style="list-style-type: none"> 84-pin plastic QFJ 80-pin plastic QFP (14 × 14 mm) 94-pin ceramic WQFN (for μPD78P238 only) 				
Assembler		RA78K2				
C compiler		CC78K2				
Real-time OS		—		RX78K2		
Screen debugger		SD78K2 DF78230				
In-circuit emulator		IE-78230-R-A				
Applications		OA equipment such as LBP, PPC, Fax, etc.				

*: Set by software

8/16-Bit Single Chip Microcontroller

78K/III Series

■ 78K/III Series Products (1/4) ▶

Series name		μPD78312A Series			μPD78322 Series					
Part number		μPD78310A	μPD78312A	μPD78P312A	μPD78320	μPD78322	μPD78P322	μPD78323	μPD78324	μPD78P324
Number of instructions		96			111					
Minimum instruction cycle		500 ns/12 MHz			250 ns/16MHz					
Internal memory	ROM size	—	8K bytes	8K bytes (PROM)	—	16K bytes	16K bytes (PROM)	—	32K bytes	32K bytes (PROM)
	RAM size	256 bytes			640 bytes			1024 bytes		
	External source	4			8					
	Internal source	14			13					
Interrupt function		<ul style="list-style-type: none"> • 8-level programmable priority • Macro service (high-speed data transfer) function • Context switching function 			<ul style="list-style-type: none"> • 3-level programmable priority • Macro service (high-speed data transfer/operation) function: 9 types • Context switching function 					
I/O pin	Input	8			16					
	Output	—								
	I/O	24	40		21	39		21	39	
Analog input		8-bit A/D converter × 4 channels			10-bit resolution × 8 channels					
Timer/counter		16-bit up/down counter × 2 channels 16-bit interval timer × 2 channels			18/16-bit free running timer × 1 channel 16-bit timer/event counter × 1 channel					
Serial interface		UART (with dedicated on-chip baud rate generator): 1 channel (Synchronous)			UART (with dedicated on-chip baud rate generator): 1 channel Synchronous (SBI capability): 1 channel					
Standby function		HALT/STOP mode								
Feature		<ul style="list-style-type: none"> • On-chip up/down counter for DC servo 			<ul style="list-style-type: none"> • Real-time pulse unit outputting multi-purpose programmable pulse signals 					
Package		<ul style="list-style-type: none"> • 64-pin plastic SDIP • 64-pin plastic QUIP • 64-pin plastic QFP • 68-pin plastic QFJ *1			<ul style="list-style-type: none"> • 68-pin plastic QFJ • 74-pin plastic QFP • 80-pin plastic QFP *2		<ul style="list-style-type: none"> • 68-pin plastic QFJ • 74-pin plastic QFP *3			
Assembler		RA78K3								
C compiler		CC78K3								
Real-time OS		—			RX78K3					
In-circuit emulator		IE-78310A-R			IE-78327-R					
Applications		Control equipment for DC servo motors, stepping motors, etc.								

- *1: • 64-pin plastic SDIP
 • 64-pin plastic QUIP
 • 64-pin plastic QFP
 • 68-pin plastic QFJ
 • 64-pin ceramic SDIP with window
 • 64-pin ceramic QUIP with window

- *2: • 68-pin plastic QFJ
 • 74-pin plastic QFP
 • 80-pin plastic QFP
 • 68-pin ceramic WQFN
 • 74-pin ceramic WQFN
 • 80-pin ceramic WQFN

- *3: • 68-pin plastic QFJ
 • 74-pin plastic QFP
 • 68-pin ceramic WQFN
 • 74-pin ceramic WQFN

8/16-Bit Single Chip Microcontroller

78K/III Series

■ 78K/III Series Products (2/4) ◀ ▶

Series name		μPD78328 Series			μPD78334 Series			μPD78350 Series				
Part number		μPD78327	μPD78328	μPD78P328	μPD78330	μPD78334	μPD78P334	μPD78350	μPD78350A	μPD78352A	μPD78P352	
Number of instructions		111						113				
Minimum instruction cycle		250 ns/16 MHz						160 ns/25 MHz		125 ns/32 MHz		
Internal memory	ROM size	—	16K bytes	16K bytes (PROM)	—	32K bytes	32K bytes (PROM)	—		32K bytes	32K bytes (PROM)	
	RAM size	512 bytes			1024 bytes			640 bytes				
External source	External source	4			8			5				
	Internal source	11			14			4				
Interrupt function		<ul style="list-style-type: none"> • 3-level programmable priority • Macro service (high-speed data transfer/operation): 10 types • Context switching function 			<ul style="list-style-type: none"> • 3-level programmable priority • Macro service (high-speed data transfer/operation) function: 8 types • Context switching function 			<ul style="list-style-type: none"> • 4-level programmable priority • Macro service (high-speed data transfer/operation) function • Context switching function 				
I/O pin	Input	11			24			6				
	Output	—			—			—				
	I/O	23	41		28	46		24		44		
Analog input		10-bit resolution × 8 channels			10-bit resolution × 16 channels			—				
Timer/counter		16-bit timer × 2 channels 16-bit timer/event counter × 1			18/16-bit free running timer × 1 channel 16-bit timer/counter × 3 channels			16-bit timer × 3 channels				
Serial interface		UART (with dedicated on-chip baud rate generator): 1 channel Synchronous (SBI capability): 1 channel						—				
Standby function		HALT/STOP mode										
Feature		6-channel PWM output function for inverter control			Real-time pulse unit supporting output of versatile programmable pulse signals			<ul style="list-style-type: none"> • High-speed sum-of-products operation function • Suitable for ASIC control 				
Package		<ul style="list-style-type: none"> • 64-pin plastic QFP • 64-pin plastic SDIP 		*	<ul style="list-style-type: none"> • 84-pin plastic QFJ • 94-pin plastic QFP 		<ul style="list-style-type: none"> • 84-pin plastic QFJ • 94-pin plastic QFP • 84-pin ceramic WQFN • 94-pin ceramic WQFN 	<ul style="list-style-type: none"> • 64-pin plastic QFP 		<ul style="list-style-type: none"> • 64-pin plastic QFP • 64-pin ceramic WQFN 		
Assembler		RA78K3						RA78K3				
C compiler		CC78K3						CC78K3				
Real-time OS		RX78K3						—				
Integrated debugger		—						ID78K3				
In-circuit emulator		IE-78327-R			IE-78330-R			IE-78350-R+IE-78350-R-EM1 (with IE controller) IE-784000-R+IE-78350-R-EM-A+IE-78350-R-EM1 (with integrated debugger)				
Applications		Inverter air-conditioners			FA field, etc.			HDDs, FDDs, etc.				

- *: • 64-pin plastic QFP
• 64-pin plastic SDIP
• 64-pin ceramic SDIP with window

8/16-Bit Single Chip Microcontroller

78K/III Series

■ 78K/III Series Products (3/4) ◀ ▶

Series name		μ PD78356 Series		
Part number		μ PD78355	μ PD78356	μ PD78P356
Number of instructions		115		
Minimum instruction cycle		125 ns/32 MHz		
Internal memory	ROM size	—	48K bytes	48K bytes(PROM)
	RAM size	2048 bytes		
	External source	5		
	Internal source	25		
Interrupt function		4-level programmable priority Macro service (high-speed data transfer/operation) function Context switching function		
I/O pin	Input	8		
	Output	—		
	I/O	49	68	
A/D converter		10-bit resolution \times 8 channels		
D/A converter		8-bit resolution \times 2 channels		
Timer/counter		16-bit timer \times 5 channels/10-bit timer \times 1 channel		
Serial interface		UART (with dedicated on-chip baud rate generator): 1 channel Synchronous (SBI capability): 1 channel Synchronous (with pin switching function): 1 channel		
Standby function		HALT/STOP mode		
Feature		<ul style="list-style-type: none"> • Very high-speed on-chip A/D converter (Conversion time: 2 μs) • Small QFP package (0.5-mm pitch, 1.45-mm thick) 		
Package		100-pin plastic QFP 120-pin plastic QFP		100-pin plastic QFP 120-pin plastic QFP 120-pin ceramic WQFN
Assembler		RA78K3		
C compiler		CC78K3		
Integrated debugger		ID78K3		
In-circuit emulator		IE-78350-R+IE-78355-R-EM1 (with IE controller) IE-784000-R+IE-78350-R-EM-A+ IE-78355-R-EM1 (with integrated debugger)		
Applications		HDDs, video camcorders, single-lens reflex cameras, etc.		

8/16-Bit Single Chip Microcontroller

78K/III Series

■ 78K/III Series Products (4/4) ◀

Series name		μPD78366A Series							
Part number		μPD78361A	μPD78362A	μPD78P364A	μPD78365A	μPD78363A	μPD78366A	μPD78368A	μPD78P368A
Number of instructions		115							
Minimum instruction cycle		125 ns/8 MHz (with on-chip PLL circuit)							
Internal memory	ROM size	32K bytes	24K bytes	48K bytes (PROM)	—	24K bytes	32K bytes	48K bytes	48K bytes(PROM)
	RAM size	2K bytes	768 bytes	2K bytes		768 byte	2K bytes		
Interrupt function	External source	6							
	Internal source	14							
Interrupt function		4-level programmable priority Macro service (high-speed data transfer/operation) function Context switching function							
I/O pin	Input	14 (Used also for analog input: 8)							
	Output	—							
	I/O	38			31		49		
A/D converter		10-bit resolution × 8 channels							
D/A converter		—							
Timer/counter		16-bit timer × 5 channels							
Serial interface		UART (with dedicated on-chip baud rate generator): 1 channel Synchronous (SBI capability): 1 channel							
Standby function		HALT/STOP mode							
Feature		<ul style="list-style-type: none"> High-speed timer with 62.5-ns resolution Real-time pulse unit suitable for inverter control (with on-chip dead time timer, capture with noise elimination function, etc.) 							
Package		64-pin plastic SDIP				80-pin plastic QFP			80-pin plastic QFP 80-pin ceramic WQFN
Assembler		RA78K3							
C compiler		CC78K3							
Integrated debugger		ID78K3							
In-circuit emulator		IE-78350-R+IE-78365-R-EM1 (with IE controller) IE-784000-R+IE-78350-R-EM-A+IE-78365-R-EM1 (with integrated debugger)							
Applications		Inverter air-conditioners, robots, machine tools, etc.							

8/16-Bit Single Chip Microcontroller

78K/IV Series

■ 78K/IV Series Products (1/16) ▶

Subseries name		μPD784026 Subseries				
Part number		μPD784020	μPD784021	μPD784025	μPD784026	μPD78P4026
Number of instructions		113				
Minimum instruction cycle		160 ns (25 MHz)				
Memory expansion function		Total of 1M bytes for both programs and data				
Internal memory	ROM size (bytes)	—		48K	64K	64K (PROM)
	RAM size (bytes)	512	2048			
Interrupt function		4-level programmable priority, macro service, vectored interrupt, context switching function				
	External source	7				
	Internal source	18				
	Number of interrupts supporting the use of a macro service	19				
	Type of macro service	4 types, 21 kinds				
I/O pin	Input	8				
	Output	4		0		
	I/O	34		56		
Timer/counter		16-bit timer/counter × 3 channels 16-bit timer × 1 channel				
Serial interface		UART/IOE (with on-chip baud rate generator): 2 channels CSI (SBI capability): 1 channel				
A/D converter		8-bit resolution × 8 channels				
D/A converter		8-bit resolution × 2 channels				
PWM output		12-bit resolution × 2 channels				
Standby function		HALT/IDLE/STOP mode				
Pseudo-SRAM refresh function		Provided				
Feature		<ul style="list-style-type: none"> • Large internal memory • Wide operating voltage range (2.7 V to 5.5 V) • System clock dividing function (1/2, 1/4, 1/8, 1/16) 				
Package		80-pin plastic QFP	80-pin plastic QFP 80-pin plastic TQFP	80-pin plastic QFP		80-pin plastic QFP 80-pin ceramic WQFN
Assembler		RA78K4				
C compiler		CC78K4				
Real-time OS		RX78K4, MX78K4				
System performance analyzer		AZ78K4				
Integrated debugger		ID78K4				
Device file		DF784026				
In-circuit emulator		IE-784000-R+IE-784000-R-EM+IE-784038-NS-EM1+IE-78K4-R-EX2 (with ID78K4) IE-78K4-NS+IE-784038-NS-EM1 (with ID78K4-NS)				
Applications		PPCs, LBPs, autofocus cameras, etc.				

8/16-Bit Single Chip Microcontroller

78K/IV Series

■ 78K/IV Series Products (2/16) ◀ ▶

Subseries name		μPD784038 Subseries					
Part number		μPD784031	μPD784035	μPD784036	μPD784037	μPD784038	μPD78P4038
Number of instructions		113					
Minimum instruction cycle		125 ns (32 MHz)					
Memory expansion function		Total of 1M bytes for both programs and data					
Internal memory	ROM size (bytes)	–	48K	64K	96K	128K	128K (PROM)
	RAM size (bytes)	2K			3.5K	4.25K	
Interrupt function		4-level programmable priority, macro service, vectored interrupt, context switching function					
	External source	7					
	Internal source	18					
	Number of interrupts supporting the use of a macro service	19					
	Type of macro service	4 types, 21 kinds					
I/O pin	Input	8					
	Output	4	0				
	I/O	34	56				
Timer/counter		16-bit timer/counter × 3 channels 16-bit timer × 1 channel					
Serial interface		UART/IOE (with on-chip baud rate generator): 2 channels CSI (3-wire/2wire mode): 1 channel					
A/D converter		8-bit resolution × 8 channels					
D/A converter		8-bit resolution × 2 channels					
PWM output		12-bit resolution × 2 channels					
Standby function		HALT/IDLE/STOP mode					
Pseudo-SRAM refresh function		Provided					
Feature		<ul style="list-style-type: none"> • Large internal memory • Wide operating voltage range (2.7 V to 5.5 V) • System clock dividing function (1/2, 1/4, 1/8, 1/16) 					
Package		80-pin plastic QFP 80-pin plastic TQFP					80-pin plastic QFP 80-pin plastic TQFP 80-pin ceramic WQFN
Assembler		RA78K4					
C compiler		CC78K4					
Real-time OS		RX78K4, MX78K4					
System performance analyzer		AZ78K4					
Integrated debugger		ID78K4 or ID78K4-NS					
Device file		DF784038					
In-circuit emulator		IE-784000-R+IE-784000-R-EM+IE-784038-NS-EM1+IE-78K4-R-EX2 (with ID78K4) IE-78K4-NS+IE-784038-NS-EM1 (with ID78K4-NS)					
Applications		PPCs, LBPs, autofocus cameras, etc.					

8/16-Bit Single Chip Microcontroller

78K/IV Series

■ 78K/IV Series Products (3/16) ◀▶

Subseries name		μPD784038Y Subseries					
Part number		μPD784031Y	μPD784035Y	μPD784036Y	μPD784037Y	μPD784038Y	μPD78P4038Y
Number of instructions		113					
Minimum instruction cycle		125 ns (32 MHz)					
Memory expansion function		Total of 1M bytes for both programs and data					
Internal memory	ROM size (bytes)	–	48K	64K	96K	128K	128K (PROM)
	RAM size (bytes)	2K			3.5K	4.25K	
Interrupt function		4-level programmable priority, macro service, vectored interrupt, context switching function					
	External source	8					
	Internal source	19					
	Number of interrupts supporting the use of a macro service	20					
	Type of macro service	4 types, 21 kinds					
I/O pin	Input	8					
	Output	4	0				
	I/O	34	56				
Timer/counter		16-bit timer/counter × 3 channels 16-bit timer × 1 channel					
Serial interface		UART/IOE (with on-chip baud rate generator): 2 channels CSI (3-wire/2-wire/I ² C bus mode): 1 channel					
A/D converter		8-bit resolution × 8 channels					
D/A converter		8-bit resolution × 2 channels					
PWM output		12-bit resolution × 2 channels					
Standby function		HALT/IDLE/STOP mode					
Pseudo-SRAM refresh function		Provided					
Feature		<ul style="list-style-type: none"> • Large internal memory • Wide operating voltage range (2.7 V to 5.5 V) • System clock dividing function (1/2, 1/4, 1/8, 1/16) 					
Package		80-pin plastic QFP 80-pin plastic TQFP				80-pin plastic QFP 80-pin plastic TQFP 80-pin ceramic WQFN	
Assembler		RA78K4					
C compiler		CC78K4					
Real-time OS		RX78K4, MX78K4					
System performance analyzer		AZ78K4					
Integrated debugger		ID78K4 or ID78K4-NS					
Device file		DF784038					
In-circuit emulator		IE-784000-R+IE-784000-R-EM+IE-784038-NS-EM1+IE-78K4-R-EX2 (with ID78K4) IE-78K4-NS+IE-784038-NS-EM1 (with ID78K4-NS)					
Applications		Cellular phones, cordless phones, AV equipment, etc.					

★: Under development

8/16-Bit Single Chip Microcontroller

78K/IV Series

■ 78K/IV Series Products (4/16) ◀ ▶

Subseries name		μPD784046 Subseries			μPD784054 Subseries
Part number		μPD784044	μPD784046	μPD78F4046	μPD784054
Number of instructions		113			
Minimum instruction cycle		125 ns (32 MHz)			
Memory expansion function		Total of 1M bytes for both programs and data			
Internal memory	ROM size (bytes)	32K	64K	64K (flash memory)	32K
	RAM size (bytes)	1024	2048	2048	1024
Interrupt function		4-level programmable priority, macro service, vectored interrupt, context switching function			
	External source	8			
	Internal source	23			19
	Number of interrupts supporting the use of a macro service	25			21
	Type of macro service	7 types, 27 kinds			7 types, 23 kinds
I/O pin	Input	17			
	Output	0			
	I/O	48			47
Timer/counter		16-bit timer × 3 channels 16-bit timer/counter × 2 channels			16-bit timer × 3
Serial interface		UART/CSI × 2 channels			
A/D converter		10-bit resolution × 16 channels			
Standby function		HALT/IDLE/STOP mode			HALT/IDLE/STOP/standby invalidation mode
Feature		On-chip timer unit optimum for real-time control			
Package		80-pin plastic QFP			
Assembler		RA78K4			
C compiler		CC78K4			
Real-time OS		RX78K4, MX78K4			
System performance analyzer		AZ78K4			
Integrated debugger		ID78K4 or ID78K4-NS			
Device file		DF784046			
In-circuit emulator		IE-784000-R+IE-784000-R-EM+IE-784046-NS-EM1+IE-78K4-R-EX2 (with ID78K4) IE-78K4-NS+IE-784046-NS-EM1 (with ID78K4-NS)			
Applications		Hot water supplier, vending machines, etc.			

8/16-Bit Single Chip Microcontroller

78K/IV Series

■ 78K/IV Series Products (5/16) ◀ ▶

Subseries name		μPD784216 Subseries			
Part number		μPD784214	μPD784215	μPD784216	μPD78F4216*
Number of instructions		113			
Minimum instruction cycle		160 ns (Main system clock 12.5 MHz)/61 μs (Subsystem clock 32.768 kHz)			
Memory expansion function		Total of 1M bytes for both programs and data			
Internal memory	ROM size (bytes)	96K	128K	128K	128K (Flash memory)
	RAM size (bytes)	3584	5120	8192	
Interrupt function		4-level programmable priority, macro service, vectored interrupt, context switching function			
	External source	9			
	Internal source	20			
	Number of interrupts supporting the use of a macro service	27			
	Type of macro service	4 types, 21kinds			
I/O pin	Input	8			
	I/O	72			
	N-ch open-drain I/O	6			
Timer/counter		16-bit timer/counter × 1 channel 8-bit timer/counter × 6 channels			
Real-time output port		4-bit × 2 ports or 8-bit × 1 port			
Serial interface		UART/IOE (with dedicated on-chip baud rate generator): 2 channels CSI (3-wire mode): 1 channel			
A/D converter		8-bit resolution × 8 channels			
D/A converter		8-bit resolution × 2 channels			
Clock output		Select of f_{xx} , $f_{xx}/2$, $f_{xx}/2^2$, $f_{xx}/2^3$, $f_{xx}/2^4$, $f_{xx}/2^5$, $f_{xx}/2^6$, $f_{xx}/2^7$, f_{XT}			
Buzzer output		Select of $f_{xx}/2^{10}$, $f_{xx}/2^{11}$, $f_{xx}/2^{12}$, $f_{xx}/2^{13}$			
Clock timer		1 channel			
Standby function		HALT/STOP/IDLE mode HALT/IDLE mode at Low power consumption mode (CPU operation using subsystem clock)			
Feature		<ul style="list-style-type: none"> • Large internal memory • Wide operation voltage range (1.8 V to 5.5 V) • Using peripheral functions of 78K/0 series 			
Package		100-pin plastic QFP (14 × 14 mm) 100-pin plastic QFP (14 × 20 mm)			
Assembler		RA78K4			
C compiler		CC78K4			
Real-time OS		RX78K4, MX78K4			
System performance analyzer		AZ78K4			
Integrated debugger		ID78K4 or ID78K4-NS			
Device file		DF784218*			
In-circuit emulator		IE-784000-R+IE-784000-R-EM+IE-784225-NS-EM1+IE-78K4-R-EX3 (with ID78K4) IE-78K4-NS+IE-784225-NS-EM1 (with ID78K4-NS)			
Applications		Cellular phones, PHS, cordless phones, CD-ROMs, AV equipment, etc.			

*: Under development

8/16-Bit Single Chip Microcontroller

78K/IV Series

■ 78K/IV Series Products (6/16) ◀▶

Subseries name		μ PD784216Y Subseries			
Part number		μ PD784214Y	μ PD784215Y	μ PD784216Y	μ PD78F4216Y*
Number of instructions		113			
Minimum instruction cycle		160 ns (Main system clock 12.5 MHz)/61 μ s (Subsystem clock 32.768 kHz)			
Memory expansion function		Total of 1M bytes for both programs and data			
Internal memory	ROM size (bytes)	96K	128K	128K	128K (Flash memory)
	RAM size (bytes)	3584	5120	8192	
Interrupt function		4-level programmable priority, macro service, vectored interrupt, context switching function			
	External source	9			
	Internal source	20			
	Number of interrupts supporting the use of a macro service	27			
	Type of macro service	4 types, 21kinds			
I/O pin	Input	8			
	I/O	72			
	N-ch open-drain I/O	6			
Timer/counter		16-bit timer/counter \times 1 channel 8-bit timer/counter \times 6 channels			
Real-time output port		4-bit \times 2 ports or 8-bit \times 1 port			
Serial interface		UART/IOE (with dedicated on-chip baud rate generator): 2 channels CSI (3-wire/I ² C bus supporting multi-master mode): 1 channel			
A/D converter		8-bit resolution \times 8 channels			
D/A converter		8-bit resolution \times 2 channels			
Clock output		Select of f_{xx} , $f_{xx}/2$, $f_{xx}/2^2$, $f_{xx}/2^3$, $f_{xx}/2^4$, $f_{xx}/2^5$, $f_{xx}/2^6$, $f_{xx}/2^7$, f_{XT}			
Buzzer output		Select of $f_{xx}/2^{10}$, $f_{xx}/2^{11}$, $f_{xx}/2^{12}$, $f_{xx}/2^{13}$			
Clock timer		1 channel			
Standby function		HALT/STOP/IDLE mode HALT/IDLE mode at Low power consumption mode (CPU operation using subsystem clock)			
Feature		<ul style="list-style-type: none"> • Large internal memory • Wide operation voltage range (1.8 V to 5.5 V) • Using peripheral functions of 78K/0 series 			
Package		100-pin plastic QFP (14 \times 14 mm) 100-pin plastic QFP (14 \times 20 mm)			
Assembler		RA78K4			
C compiler		CC78K4			
Real-time OS		RX78K4, MX78K4			
System performance analyzer		AZ78K4			
Integrated debugger		ID78K4 or ID78K4-NS			
Device file		DF784218*			
In-circuit emulator		IE-784000-R+IE-784000-R-EM+IE-784225-NS-EM1+IE-78K4-EX3 (with ID78K4) IE-78K4-NS+IE-784225-NS-EM1 (with ID78K4-NS)			
Applications		Cellular phones, PHS, cordless phones, CD-ROMs, AV equipment, etc.			

*: Under development

8/16-Bit Single Chip Microcontroller

78K/IV Series

■ 78K/IV Series Products (7/16) ◀▶

Subseries name		μ PD784218 Subseries		
Part number		μ PD784217*	μ PD784218*	μ PD78F4218*
Number of instructions		113		
Minimum instruction cycle		160 ns (Main system clock 12.5 MHz)/61 μ s (Subsystem clock 32.768 kHz)		
Memory expansion function		Total of 1M bytes for both programs and data		
Internal memory	ROM size (bytes)	192K	256K	256K (Flash memory)
	RAM size (bytes)	12800		
Interrupt function		4-level programmable priority, macro service, vectored interrupt, context switching function		
	External source	9		
	Internal source	20		
	Number of interrupts supporting the use of a macro service	27		
	Type of macro service	4 types, 21 kinds		
I/O pin	Input	8		
	I/O	72		
	N-ch open-drain I/O	6		
Timer/counter		16-bit timer/counter \times 1 channel 8-bit timer/counter \times 6 channels		
Real-time output port		4-bit \times 2 ports or 8-bit \times 1 port		
Serial interface		UART/IOE (with dedicated on-chip baud rate generator): 2 channels CSI (3-wire mode): 1 channel		
A/D converter		8-bit resolution \times 8 channels		
D/A converter		8-bit resolution \times 2 channels		
Clock output		Select of f_{xx} , $f_{xx}/2$, $f_{xx}/2^2$, $f_{xx}/2^3$, $f_{xx}/2^4$, $f_{xx}/2^5$, $f_{xx}/2^6$, $f_{xx}/2^7$, f_{xt}		
Buzzer output		Select of $f_{xx}/2^{10}$, $f_{xx}/2^{11}$, $f_{xx}/2^{12}$, $f_{xx}/2^{13}$		
Clock timer		1 channel		
Standby function		HALT/STOP/IDLE mode HALT/IDLE mode at Low power consumption mode (CPU operation using subsystem clock)		
Feature		<ul style="list-style-type: none"> • Large internal memory • Wide operation voltage range (1.8 to 5.5 V) • Using peripheral functions of 78K/0 series 		
Package		100-pin plastic QFP (14 \times 20 mm, 0.65-mm pitch) 100-pin plastic QFP (14 \times 14 mm, 0.5-mm pitch)		
Assembler		RA78K4		
C compiler		CC78K4		
Real-time OS		RX78K4, MX78K4		
System performance analyzer		AZ78K4		
Integrated debugger		ID78K4 or ID78K4-NS		
Device file		DF784218*		
In-circuit emulator		IE-784000-R+IE-784000-R-EM+IE-784225-NS-EM1+IE-78K4-R-EX3 (with ID78K4) IE-78K4-NS+IE-784225-NS-EM1 (with ID78K4-NS)		
Applications		Cellular phones, PHS, cordless phones, CD-ROMs, AV equipment, etc.		

*: Under development

8/16-Bit Single Chip Microcontroller

78K/IV Series

■ 78K/IV Series Products (8/16) ◀▶

Subseries name		μPD784218Y Subseries		
Part number		μPD784217Y*	μPD784218Y*	μPD78F4218Y*
Number of instructions		113		
Minimum instruction cycle		160 ns (Main system clock 12.5 MHz)/61 μs (Subsystem clock 32.768 kHz)		
Memory expansion function		Total of 1M bytes for both programs and data		
Internal memory	ROM size (bytes)	192K	256K	256K (Flash memory)
	RAM size (bytes)	12800		
Interrupt function		4-level programmable priority, macro service, vectored interrupt, context switching function		
	External source	9		
	Internal source	20		
	Number of interrupts supporting the use of a macro service	27		
	Type of macro service	4 types, 21 kinds		
I/O pin	Input	8		
	I/O	72		
	N-ch open-drain I/O	6		
Timer/counter		16-bit timer/counter × 1 channel 8-bit timer/counter × 6 channels		
Real-time output port		4-bit × 2 ports or 8-bit × 1 port		
Serial interface		UART/IOE (with dedicated on-chip baud rate generator): 2 channels CSI (3-wire/I ² C bus supporting multi-master mode): 1 channel		
A/D converter		8-bit resolution × 8 channels		
D/A converter		8-bit resolution × 2 channels		
Clock output		Select of f_{xx} , $f_{xx}/2$, $f_{xx}/2^2$, $f_{xx}/2^3$, $f_{xx}/2^4$, $f_{xx}/2^5$, $f_{xx}/2^6$, $f_{xx}/2^7$, f_{XT}		
Buzzer output		Select of $f_{xx}/2^{10}$, $f_{xx}/2^{11}$, $f_{xx}/2^{12}$, $f_{xx}/2^{13}$		
Clock timer		1 channel		
Standby function		HALT/STOP/IDLE mode HALT/IDLE mode at Low power consumption mode (CPU operation using subsystem clock)		
Feature		<ul style="list-style-type: none"> • Large internal memory • Wide operation voltage range (1.8 to 5.5 V) • Using peripheral functions of 78K/0 series 		
Package		100-pin plastic QFP (14 × 20 mm, 0.65-mm pitch) 100-pin plastic LQFP (14 × 14 mm, 0.5-mm pitch)		
Assembler		RA78K4		
C compiler		CC78K4		
Real-time OS		RX78K4, MX78K4		
System performance analyzer		AZ78K4		
Integrated debugger		ID78K4 or ID78K4-NS		
Device file		DF784218*		
In-circuit emulator		IE-784000-R+IE-784000-R-EM+IE-784225-NS-EM1+IE-78K4-R-EX3 (with ID78K4) IE-78K4-NS+IE-784225-NS-EM1 (with ID78K4-NS)		
Applications		Cellular phones, PHS, cordless phones, CD-ROMs, AV equipment, etc.		

*: Under development

8/16-Bit Single Chip Microcontroller

78K/IV Series

■ 78K/IV Series Products (9/16) ◀▶

Subseries name		μ PD784225 Subseries		
Part number		μ PD784224*	μ PD784225*	μ PD78F4225*
Number of instructions		113		
Minimum instruction cycle		160 ns (Main system clock 12.5 MHz)/61 μ s (Subsystem clock 32.768 kHz)		
Memory expansion function		Total of 1M bytes for both programs and data		
Internal memory	ROM size (bytes)	96K	128K	128K (Flash memory)
	RAM size (bytes)	3584	4352	
Interrupt function		4-level programmable priority, macro service, vectored interrupt, context switching function		
	External source	7		
	Internal source	18		
	Number of interrupts supporting the use of a macro service	23		
	Type of macro service	4 types, 21 kinds		
I/O pin	Input	8		
	I/O	59		
Timer/counter		16-bit timer/counter \times 1 channel 8-bit timer/counter \times 4 channels		
Real-time output port		4-bit \times 2 ports or 8-bit \times 1 port		
Serial interface		UART/IOE (with dedicated on-chip baud rate generator): 2 channels CSI (3-wire mode): 1 channel		
A/D converter		8-bit resolution \times 8 channels		
D/A converter		8-bit resolution \times 2 channels		
Clock output		Select of f_{xx} , $f_{xx}/2$, $f_{xx}/2^2$, $f_{xx}/2^3$, $f_{xx}/2^4$, $f_{xx}/2^5$, $f_{xx}/2^6$, $f_{xx}/2^7$, f_{XT}		
Buzzer output		Select of $f_{xx}/2^{10}$, $f_{xx}/2^{11}$, $f_{xx}/2^{12}$, $f_{xx}/2^{13}$		
Clock timer		1 channel		
Standby function		HALT/STOP/IDLE mode HALT/IDLE mode at Low power consumption mode (CPU operation using subsystem clock)		
Feature		<ul style="list-style-type: none"> • Large internal memory • Wide operation voltage range (1.8 to 5.5 V) • Using peripheral functions of 78K/0 series 		
Package		80-pin plastic QFP (14 \times 14 mm) 80-pin plastic TQFP (12 \times 12 mm)		
Assembler		RA78K4		
C compiler		CC78K4		
Real-time OS		RX78K4, MX78K4		
System performance analyzer		AZ78K4		
Integrated debugger		ID78K4 or ID78K4-NS		
Device file		DF784225*		
In-circuit emulator		IE-784000-R+IE-784000-R-EM+IE-784225-NS-EM1+IE-78K4-R-EX2 (with ID78K4) IE-78K4-NS+IE-784225-NS-EM1 (with ID78K4-NS)		
Applications		Car audio, portable audio, telephones, etc.		

* : Under development

8/16-Bit Single Chip Microcontroller

78K/IV Series

■ 78K/IV Series Products (10/16) ◀▶

Subseries name		μ PD784225Y Subseries		
Part number		μ PD784224Y*	μ PD784225Y*	μ PD78F4225Y*
Number of instructions		113		
Minimum instruction cycle		160 ns (Main system clock 12.5 MHz)/61 μ s (Subsystem clock 32.768 kHz)		
Memory expansion function		Total of 1M bytes for both programs and data		
Internal memory	ROM size (bytes)	96K	128K	128K (Flash memory)
	RAM size (bytes)	3584	4352	
Interrupt function		4-level programmable priority, macro service, vectored interrupt, context switching function		
	External source	7		
	Internal source	18		
	Number of interrupts supporting the use of a macro service	23		
	Type of macro service	4 types, 21 kinds		
I/O pin	Input	8		
	I/O	59		
Timer/counter		16-bit timer/counter \times 1 channel 8-bit timer/counter \times 4 channels		
Real-time output port		4-bit \times 2 ports or 8-bit \times 1 port		
Serial interface		UART/IOE (with dedicated on-chip baud rate generator): 2 channels CSI (3-wire mode): 1 channel		
A/D converter		8-bit resolution \times 8 channels		
D/A converter		8-bit resolution \times 2 channels		
Clock output		Select of f_{xx} , $f_{xx}/2$, $f_{xx}/2^2$, $f_{xx}/2^3$, $f_{xx}/2^4$, $f_{xx}/2^5$, $f_{xx}/2^6$, $f_{xx}/2^7$, f_{xt}		
Buzzer output		Select of $f_{xx}/2^{10}$, $f_{xx}/2^{11}$, $f_{xx}/2^{12}$, $f_{xx}/2^{13}$		
Clock timer		1 channel		
Standby function		HALT/STOP/IDLE mode HALT/IDLE mode at Low power consumption mode (CPU operation using subsystem clock)		
Feature		<ul style="list-style-type: none"> • Large internal memory • Wide operation voltage range (1.8 to 5.5 V) • Using peripheral functions of 78K/0 series 		
Package		80-pin plastic QFP (14 \times 14 mm) 80-pin plastic TQFP (12 \times 12 mm)		
Assembler		RA78K4		
C compiler		CC78K4		
Real-time OS		RX78K4, MX78K4		
System performance analyzer		AZ78K4		
Integrated debugger		ID78K4 or ID78K4-NS		
Device file		DF784225*		
In-circuit emulator		IE-784000-R+IE-784000-R-EM+IE-784225-NS-EM1+IE-78K4-R-EX2 (with ID78K4) IE-78K4-NS+IE-784225-NS-EM1 (with ID78K4-NS)		
Applications		Car audio, portable audio, telephones, etc.		

*: Under development

8/16-Bit Single Chip Microcontroller

78K/IV Series

■ 78K/IV Series Products (11/16) ◀ ▶

Subseries name		μPD784915 Subseries				
Part number		μPD784915, 784915A	μPD784915B	μPD784916A	μPD784916B	μPD78P4916
Number of instructions		113				
Minimum instruction cycle		250 ns (Internal clock: 8 MHz)				
Internal memory	ROM size (bytes)	48K		62K		62K (PROM)
	RAM size (bytes)	1280				2048
Interrupt function		4 levels (programmable), vectored interrupt, macro service, vectored interrupt, context switching function				
		External source		9 (including NMI)		
		Internal source		20 (including software interrupts)		
I/O pin	Input	8				
	Output	0				
	I/O	46				
Real-time output port		11 (including pseudo V sync, head amplifier switch, chroma-rotation outputs)				
Super timer unit	Timer/counter	22-bit FRC counter × 1 channel 16-bit timer × 6 channels (including 3 channels for general-purpose timers) 8-bit counter × 2 channels 5-bit UDC counter × 1 channel				
	Special circuit for VCR	V sync separator circuit, H sync separator circuit VISS detection circuit, wide aspect detection circuit Field identification circuit Head amplifier switch/chroma-rotation output circuit				
	PWM output	16-bit resolution × 3 channels (Carrier frequency: 62.5 kHz) 8-bit resolution × 3 channels (Carrier frequency: 62.5 kHz)				
Serial interface		Synchronous serial interface (3-wire): 2 channels (including 1 channel supporting BUSY/STRB control)				
A/D converter		8-bit resolution × 12 channels (Conversion time: 10 μs)				
Analog VCR circuits		CTL amplifier, RECCTL driver (with rewrite capability) CFG amplifier DFG amplifier, DPG comparator, DPG separator circuit (3-value separator circuit) Reel FG comparator (2 channels) Csync comparator				
Standby function		HALT/STOP mode HALT mode for low power consumption				
Clock function		0.5-second measurement, low voltage operation ($V_{DD} = 2.7$ V) allowed				
Package		100-pin plastic QFP (14 × 20 mm)				
Assembler		RA78K4				
C compiler		CC78K4				
Integrated debugger		ID78K4 or ID78K4-NS				
Device file		DF784915				
In-circuit emulator		IE-784000-R+IE-784000-R-EM+IE-784928-NS-EM1+IE-78K4-R-EX3 (with ID78K4) IE-78K4-NS+IE-784928-NS-EM1 (with ID78K4-NS)				
Applications		VCRs, camcorder, integrated TV-VCR machines, etc.				

8/16-Bit Single Chip Microcontroller

78K/IV Series

■ 78K/IV Series Products (12/16) ◀ ▶

Subseries name		μPD784928 Subseries		
Part number		μPD784927*	μPD784928*	μPD78F4928*
Number of instructions		113		
Minimum instruction cycle		250 ns (Internal clock: 8 MHz)		
Internal memory	ROM size (bytes)	96K	128K	128K (Flash memory)
	RAM size (bytes)	2048	3584	
Interrupt function		4 levels (programmable), vectored interrupt, macro service, context switching function		
		External source	9 (including NMI)	
		Internal source	22 (including software interrupts)	
I/O pin	Input	20		
	Output	0		
	I/O	54		
Real-time output port		11 (including pseudo V sync, head amplifier switch, chroma-rotation outputs)		
Super timer unit	Timer/counter	22-bit FRC counter × 1 channel 16-bit timer × 6 channels (including 3 channels for general-purpose timers) 8-bit counter × 2 channels 5-bit UDC counter × 1 channel		
	Special circuit for VCR	V sync separator circuit, H sync separator circuit VISS detection circuit, wide aspect detection circuit Field identification circuit Head amplifier switch/chroma-rotation output circuit		
	PWM output	16-bit resolution × 3 channels (Carrier frequency: 62.5 kHz) 8-bit resolution × 3 channels (Carrier frequency: 62.5 kHz)		
Serial interface		Synchronous serial interface (3-wire): 2 channels (including 1 channel supporting BUSY/STRB control)		
A/D converter		8-bit resolution × 12 channels (Conversion time: 10 μs)		
Analog VCR circuits		CTL amplifier, RECCTL driver (with rewrite capability) CFG amplifier DFG amplifier, DPG amplifier, DPGF separator circuit (3-value separator circuit) Reel FG comparator (2 channels) Csync comparator		
Standby function		HALT/STOP mode Low power consumption mode/HALT mode for low power consumption		
Clock function		0.5-second measurement, low voltage operation (V _{DD} = 2.7 V) allowed		
Package		100-pin plastic QFP (14 × 20 mm)		
Assembler		RA78K4		
C compiler		CC78K4		
Integrated debugger		ID78K4 or ID78K4-NS		
Device file		DF784928		
In-circuit emulator		IE-784000-R+IE-784000-R-EM+IE-784928-NS-EM1+IE-78K4-EX3 (with ID78K4) IE-78K4-NS+IE-784928-NS-EM1 (with ID78K4-NS)		
Applications		VCRs, camcorder, integrated TV-VCR machines, etc.		

★: Under development

8/16-Bit Single Chip Microcontroller

78K/IV Series

■ 78K/IV Series Products (13/16) ◀ ▶

Subseries name		μPD784928Y Subseries		
Part number		μPD784927Y*	μPD784928Y*	μPD78F4928Y*
Number of instructions		113		
Minimum instruction cycle		250 ns (Internal clock: 8 MHz)		
Internal memory	ROM size (bytes)	96K	128K	128K (Flash memory)
	RAM size (bytes)	2048	3584	
Interrupt function		4 levels (programmable), vectored interrupt, macro service, context switching function		
External source		9 (including NMI)		
Internal source		23 (including software interrupts)		
I/O pin	Input	20		
	Output	0		
	I/O	54		
Real-time output port		11 (including pseudo V sync, head amplifier switch, chroma-rotation outputs)		
Super timer unit	Timer/counter	22-bit FRC counter × 1 channel 16-bit timer × 6 channels (including 3 channels for general-purpose timers) 8-bit counter × 2 channels 5-bit UDC counter × 1 channel		
	Special circuit for VCR	V sync separator circuit, H sync separator circuit VISS detection circuit, wide aspect detection circuit Field identification circuit Head amplifier switch/chroma-rotation output circuit		
	PWM output	16-bit resolution × 3 channels (Carrier frequency: 62.5 kHz) 8-bit resolution × 3 channels (Carrier frequency: 62.5 kHz)		
Serial interface		Synchronous serial interface (3-wire): 2 channels (including 1 channel supporting BUSY/STRB control) I ² C bus interface: 1 channel		
A/D converter		8-bit resolution × 12 channels (Conversion time: 10 μs)		
Analog VCR circuits		CTL amplifier, RECCTL driver (with rewrite capability) CFG amplifier DFG amplifier, DPG amplifier, DPGF separator circuit (3-value separator circuit) Reel FG comparator (2 channels) Csync comparator		
Standby function		HALT/STOP mode Low power consumption mode/HALT mode for low power consumption		
Clock function		0.5-second measurement, low voltage operation (V _{DD} = 2.7 V) allowed		
Package		100-pin plastic QFP (14 × 20 mm)		
Assembler		RA78K4		
C compiler		CC78K4		
Integrated debugger		ID78K4 or ID78K4-NS		
Device file		DF784928		
In-circuit emulator		IE-784000-R+IE-784000-R-EM+IE-784928-NS-EM1+IE-78K4-R-EX3 (with ID78K4) IE-78K4-NS+IE-784928-NS-EM1 (with ID78K4-NS)		
Applications		VCRs, camcorder, integrated TV-VCR machines, etc.		

*: Under development

8/16-Bit Single Chip Microcontroller

78K/IV Series

■ 78K/IV Series Products (14/16) ◀ ▶

Subseries name		μ PD784908 Subseries		
Part number		μ PD784907	μ PD784908	μ PD78P4908
Number of instructions		113		
Minimum instruction cycle		160 ns (12.58 MHz)		
Memory expansion function		Total of 1M bytes for both programs and data		
Internal memory	ROM size (bytes)	96K	128K	128K (PROM)
	RAM size (bytes)	3584	4352	
Interrupt function		4-level programmable priority, macro service, vectored interrupt, context switching function		
	External source	7		
	Internal source	20		
I/O pin	Input	8		
	I/O	72		
	LED direct drive output	24		
	Transistor direct drive	8		
	N-ch open-drain I/O	4		
Timer/counter		16-bit timer/counter \times 4 channels		
Real-time output port		4-bit \times 2 ports or 8-bit \times 1 port		
IEBus controller		Internal		
Serial interface		UART/IOE (with dedicated on-chip baud rate generator): 2 channels CSI (3-wire): 2 channels		
A/D converter		8-bit resolution \times 8 channels		
PWM output		12-bit resolution \times 2 channels		
Clock output		Select of f_{xx} , $f_{xx}/2$, $f_{xx}/2^2$, $f_{xx}/2^3$, $f_{xx}/2^4$		
Watchdog timer		1 channel		
Standby function		HALT/STOP/IDLE mode		
Package		100-pin plastic QFP (14 \times 20 mm)		
Assembler		RA78K4		
C compiler		CC78K4		
Real-time OS		RX78K4, MX78K4		
System simulator		SM78K4		
Integrated debugger		ID78K4 or ID78K4-NS		
Device file		DF784908		
In-circuit emulator		IE-784000-R+IE-784000-R-EM+IE-784908-NS-EM1+IE-78K4-R-EX3 (with ID78K4) IE-78K4-NS+IE-784908-NS-EM1 (with ID78K4-NS)		
Applications		Car audio, etc.		

8/16-Bit Single Chip Microcontroller

78K/IV Series

■ 78K/IV Series Products (15/16) ◀ ▶

Subseries name		μPD784937 Subseries			
Part number		μPD784935*	μPD784936*	μPD784937*	μPD78F4937*
Number of instructions		113			
Minimum instruction cycle		160 ns (12.58 MHz)			
Memory expansion function		Total of 1M bytes for both programs and data			
Internal memory	ROM size (bytes)	96K	128K	192K	192K (Flash memory)
	RAM size (bytes)	5120	6656	8192	
Interrupt function		4-level programmable priority, macro service, vectored interrupt, context switching function			
	External source	7			
	Internal source	20			
I/O pin	Input	8			
	I/O	72			
	LED direct drive output	24			
	Transistor direct drive	8			
	N-ch open-drain I/O	4			
Timer/counter		16-bit timer/counter × 4 channels			
Real-time output port		4-bit × 2 ports or 8-bit × 1 port			
IEBus controller		Internal			
Serial interface		UART/IOE (with dedicated on-chip baud rate generator): 2 channels CSI (3-wire): 2 channels			
A/D converter		8-bit resolution × 8 channels			
PWM output		12-bit resolution × 2 channels			
Clock output		Select of f_{xx} , $f_{xx}/2$, $f_{xx}/2^2$, $f_{xx}/2^3$, $f_{xx}/2^4$			
Watchdog timer		1 channel			
Standby function		HALT/STOP/IDLE mode			
Package		100-pin plastic QFP (14 × 20 mm, 0.65-mm pitch) 100-pin plastic LQFP (14 × 14 mm, 0.5-mm pitch)			
Assembler		RA78K4			
C compiler		CC78K4			
Real-time OS		RX78K4, MX78K4			
System simulator		SM78K4			
Integrated debugger		ID78K4 or ID78K4-NS			
Device file		DF784937*			
In-circuit emulator		IE-784000-R+IE-784000-R-EM+IE-784937-NS-EM1*+IE78K4-R-EX3 (with ID78K4) IE-78K4-NS+IE-784937-NS-EM1* (with ID78K4-NS)			
Applications		Car audio, etc.			

*: Under development

8/16-Bit Single Chip Microcontroller

78K/IV Series

■ 78K/IV Series Products (16/16) ◀

Subseries name		μPD784955 Subseries		
Part number		μPD784953*	μPD784955*	μPD78F4956*
Number of instructions		113		
Minimum instruction cycle		160 ns (Internal 12.5 MHz)		
Internal memory	ROM size (bytes)	24K	48K	64K (Flash memory)
	RAM size (bytes)	768	2048	
Interrupt function		4-level programmable priority, macro service, vectored interrupt, context switching function		
	External source	8 (Also internal source: 2)		
	Internal source	22		
I/O pin	Input	8		
	I/O	59		
	Pin with pull-up register	59		
	LED direct drive output	32		
Timer/counter		16-bit timer/counter × 6 channels 8-bit timer/counter × 2 channels		
Serial interface		Synchronous serial interface (3-wire): 1 channel UART: 1 channel		
A/D converter		8-bit resolution × 8 channels		
Watchdog timer		1 channel		
Standby function		HALT/STOP/IDLE mode		
Package		80-pin plastic QFP (14 × 14 mm, 1.4 mm thick)		
Assembler		RA78K4		
C compiler		CC78K4		
Real-time OS		RX78K4, MX78K4		
System simulator		SM78K4		
Integrated debugger		ID78K4 or ID78K4-NS		
Device file		DF784956*		
In-circuit emulator		IE-784000-R+IE-784000-R-EM+IE-784956-NS-EM1+IE-78K4-R-EX2 (with ID78K4) IE-78K4-NS+IE-784956-NS-EM1 (with ID78K4-NS)		
Applications		Motor control for inverter air-conditioners, etc.		

*: Under development